



CHAMPION DISTRIBUTORS LLC

INSTALLATION MANUAL & OPERATION INSTRUCTIONS

TP6K-PL



Catalog

1.Introduction.....	- 3 -
1.1 Summarize	- 3 -
1.2 Statement	- 3 -
2.The introduction of the device	- 4 -
2.1 Device description	- 4 -
2.2 Device outline size.....	- 4 -
2.3 Device parameter	- 5 -
3.Device transportation	- 5 -
4.Device assembly.....	- 5 -
4.1 Matters need attention.....	- 5 -
4.2 Device layout	- 6 -
4.3 Tools to install the device	- 7 -
4.4 Installation steps	- 7 -
5.The introduction of the control system	- 21 -
5.1 Control theory.....	- 21 -
5.2 Control matters need attention.....	- 21 -
5.3 Parts of control problem	- 22 -
6.Device usage.....	- 23 -
6.1 Attention item	- 23 -
6.2 Parking.....	- 24 -
6.3 Take the car.....	- 24 -
7.maintenance and service of device.....	- 25 -
7.1 Overhaul	- 25 -
7.2 Common fault and repair method	- 26 -

1.Introduction

1.1 Summarize

TP6K-PL is the two-post hydraulic parking device. You should read the manual carefully before you install and assemble the device, which can help you assemble and use the device in a correct way to avoid the risk and improve the reliability and life of the device.

We will never take responsibility for the damage of the device, car and personnel caused by the operation that neglect the manual or the operation fails to submit the operation regulation.

1.2 Statement

- The operator should operate the device according to the manual, or the operator should hold responsibility for any person who is damaged and injures themselves.
- To secure safety use, the operator of the lift should be trained professionally, and have his own strong sense of responsibility. It is forbidden to operate and repair the device before reading the manual in detail or check the safety of the device in detail.

2.The introduction of the device

2.1 Device description

The TP6K-PL hydraulic parking device is a parking product that was developed through continuous research. The device enjoys great popularity with the features of simple structure, easy assembling and space-saving.

The device mainly consists of posts on two sides, carriage of two sides, and wave plate platform. The left and right post can be used in common. The left and right carriage can form double-linked or multi-linked device with the column at random.

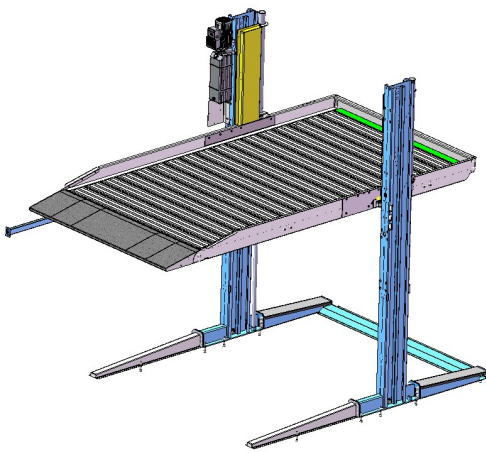

diagram (1) single set

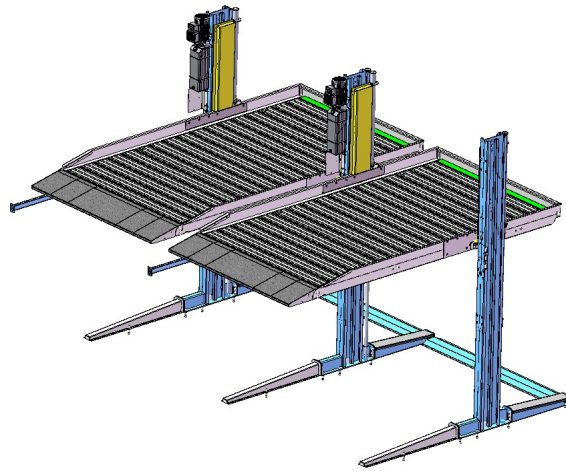

diagram (2) double-linked unit

2.2 Device outline size

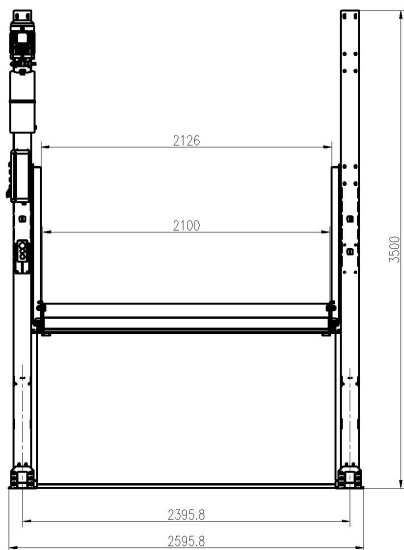

diagram (3)

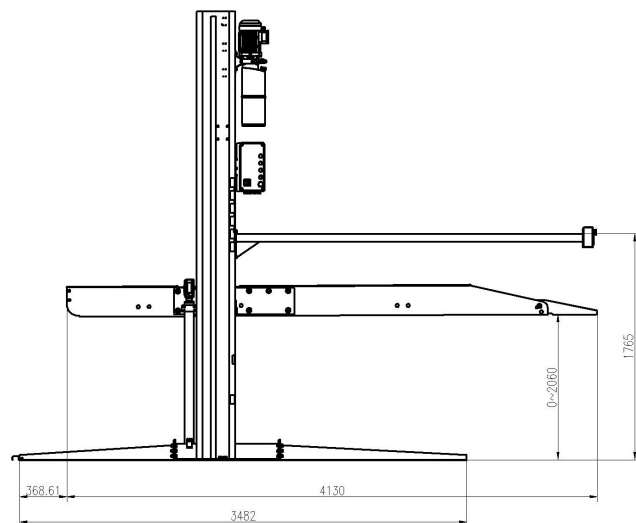

diagram (4)

Attention: The size of the device that is made according to the requirement of the customer should be based on the real size of the device.

2.3 Device parameter

Rated lifting load: 2.7 tons (about 5947 pounds)

Rated maximum lifting height: 2.06meters (about 81 inches)

3.Device transportation

The seller has packaged the equipment using packing frame, straps and paper board to avoid damage during transportation.

Please check if there is any damage or shortage when the user receives the equipment. Please record the damage or shortage in document related to find out the reason and guarantee the benefit of the user.

The device will be loose during the jolt of transportation. Before you cut the packing belt used to fix the device, to avoid of the personnel damage caused by the fallen device.

4.Device assembly

4.1 Matters need attention

4.1.1 Before install the device, read and learn the safety warning in detail.

4.1.2 Keep the working site clean and tidy.

4.1.3 Check the working environment of the device. don't expose the device in the rain, don't use the device in the damp environment. keep good ventilation and enough light in the use area.

4.1.4 Only a trained person can operate the parking equipment. The staff untrained should keep away from the working area. All the staff without training are forbidden to operate the lift.

4.1.5 The motor must be grounded to avoid electric shock.

4.1.6 Warning: the power pack voltage of the lift is so high, power off when assemble the device, to secure the safety.

4.1.7 keep smart during work to avoid injury. prevent being crushed when the device falls or topples.

4.1.8 Operate the equipment in a normal way. Do not modify the equipment using parts which are not from our company.

4.1.9 Prohibit dismantling any parts related to safety.

4.1.10 Safety locking devices should be well protected.

4.1.11 When lifting or lowering the vehicle, keep personnel away to a safe area.

4.1.12 keep enough space away from the device in case the vehicle on the device is in danger.

4.1.13 Warning: The working area should not be flammable as there is an electric spark when the switch works.

4.1.14  This mark means safety warning.

4.1.15 Keep the equipment clean and keep regular maintenance. Appropriate lubrication and maintenance help the reliability of the equipment.

4.1.16 Keep handlebar and button clean and dry to avoid the oil and grease on the device.

4.1.17 Check the synchronous situation of the left and right carriage and check if there are any damaged parts, if there is any abnormal situation, you should stop and exclude the fault.

4.2 Device layout

Before you install the lift, you should check the following items:

4.2.1 The working area should be well designed and have enough space.

4.2.2 Avoid barrier like electric wire to exist in installing area.

4.2.3 Check carefully if there is crack on the concrete ground that install the lift and check if the strength of the concrete can reach the requirements. The compressive strength should be no less than 200kg/cm². And the thickness of concrete basement should be no less than 300mm, the strength should be no less than 250 class, the just finished concrete basement must be solidified and kept over 28 days. Otherwise, the lift will crush the ground, which will cause the damage of equipment and injury & death of people.

4.2.4 The installation basement must assure certain levelness; the tolerance is not allowed over 5mm, the tolerance within this limit can be adjusted by using washers. If the ground is uneven seriously, you should fix it up.

4.2.5 Not allow to install equipment on the pitch ground or other non-concrete ground.

4.2.6 Prohibit installing equipment on the ground with craze or junk concrete ground.

4.2.7 Prohibit installing equipment on second floor or higher floor without the approval of

architect.

4.2.8 If there are no protective measures, please do not install the equipment outdoor to avoid something wrong with the motor on rainy days.

4.2.9 Confirm the general installation position of the equipment, and then put columns and platform on their respective places. Place the platform between the two columns.

4.2.10 Confirm the location of the electric cabinet and keep enough space for operation.

4.2.11 Draw up the position of the baseboard of the column with chalk after the confirmation to assure the tolerance within 3mm to avoid effecting the installation of the lift.

4.2.12 Check carefully to ensure the layout is correct.

4.3 Tools to install the device

Hammer、 Level、 Open spanner、 Socket head wrench、 Adjustable spanner、 Crowbar
Chalk or color pen、 Flat screwdriver、 Tape measure (5m)、 Nipper pliers

4.4 Installation steps

4.4.1 Install the inversion cylinder and oil hose. Place the column on the ground, remove the carriage to the top of the column, then work the oil hose 1 into from up to the bottom, and out from the square hole on the bottom, and then place the bottom end of the cylinder on the circle hole of the tray, fix the top end of the piston rod on the cylinder fixed support. And then connect the oil hose 2 with the top end of the piston rod. Then move the carriage to the bottom of the column to make the tray connect with the retainer ring of the cylinder. Likewise, place another side on the ground evenly, and install the second cylinder.

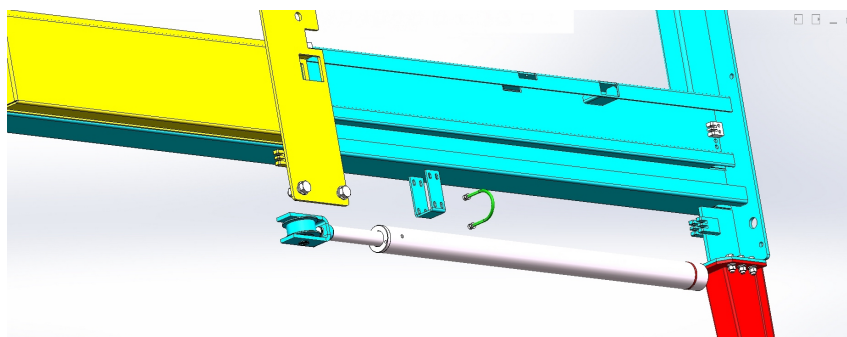

diagram (5)

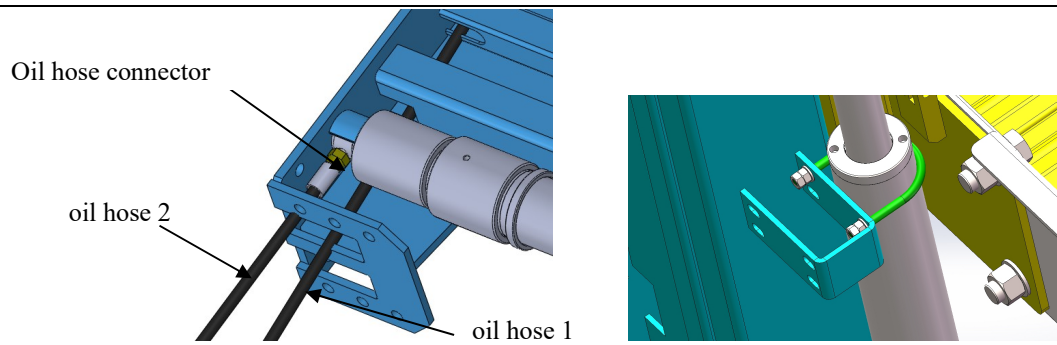

diagram (6)

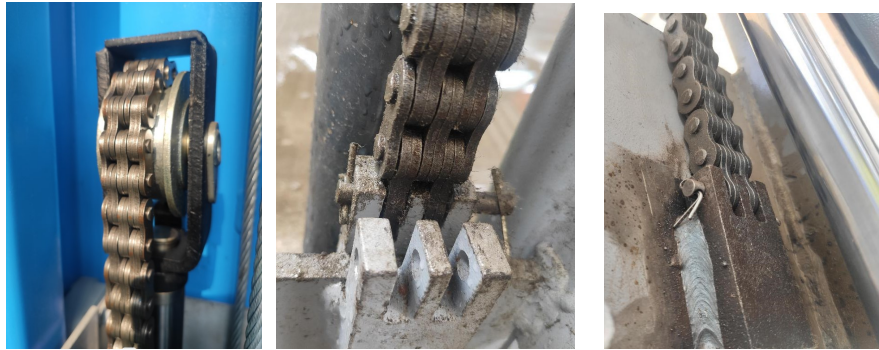

diagram (7)

4.4.2 Firstly connect the left side beam, right side beam and platform rear baffle together, and then install the rear cover, install 16 wave plate in turn, at last install front plate to driven car on, after installation, conduct diagonal adjustment to make the distance between the two diagonal lines less than 20mm.

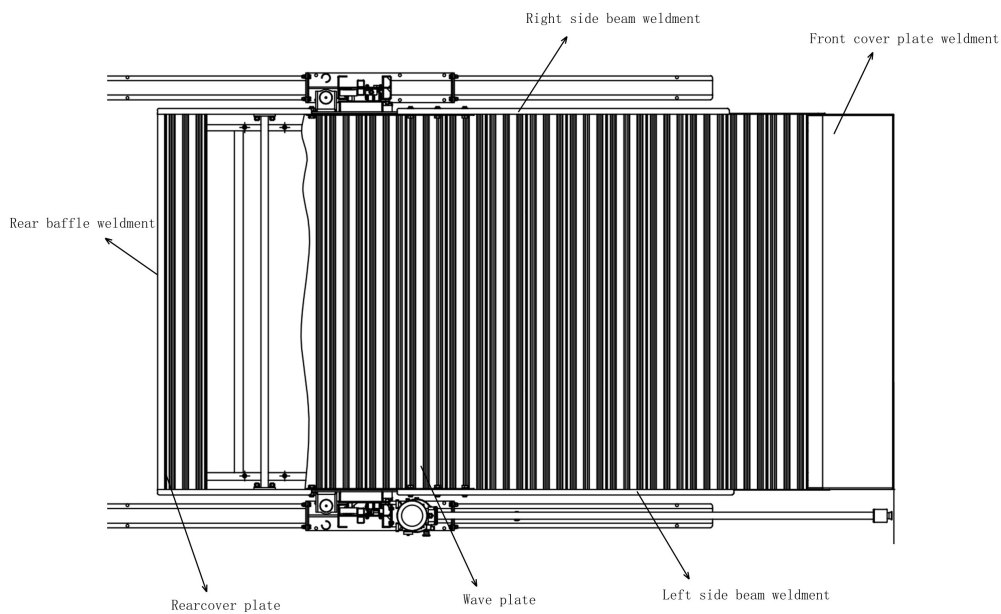
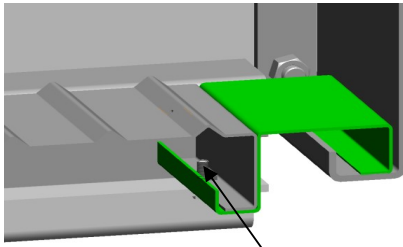
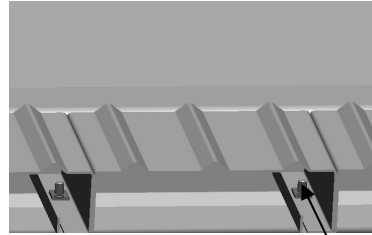

diagram (8) wave plate platform form



Hexagon head bolt outside with full
and coarse screw M16X40
Serrated lock washers M8X25

diagram (9) rear cover installation



Hexagon head bolt outside with full
and coarse screw M16X40
Serrated lock washers M8X25

diagram (10) wave plate installation

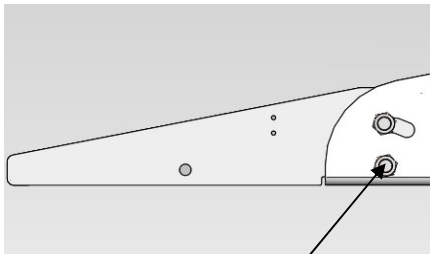

Rotation shaft 1
Grade A Type I Hexagon nut with coarse
screw M16

diagram (11) front cover installation

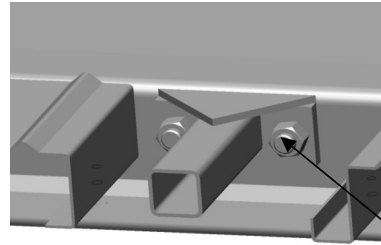

Hexagon head bolt with full
and coarse screw M16X100
Serrated lock washer external teeth 16

diagram (12) platform pull rod installation

4.4.3 Erect up the column, connect the column base support and the column with the bolt on the front leg of column and the oil hose guide slot. Connect the carriage connection plate and the platform side beam with the bolt.

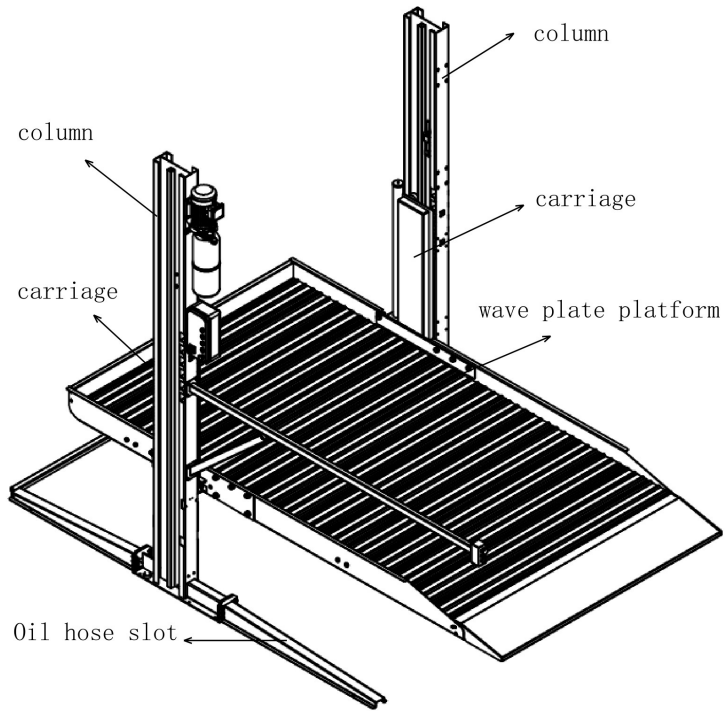
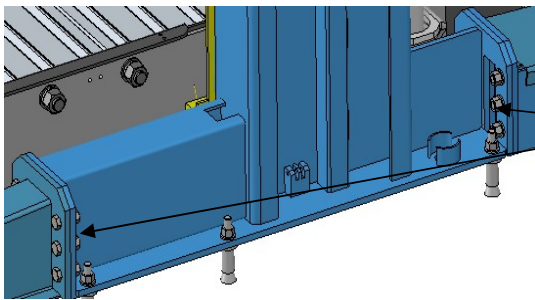
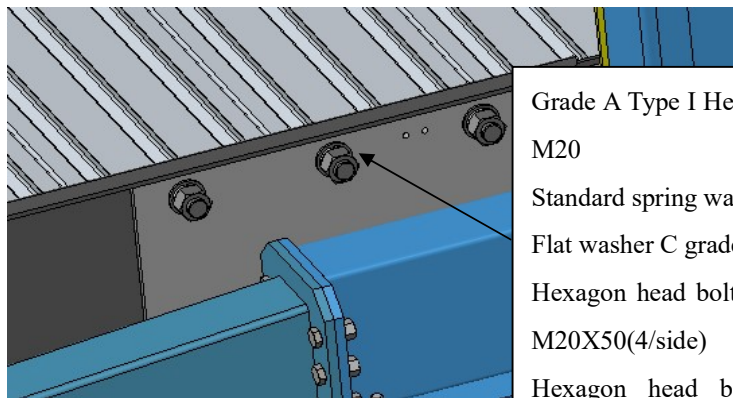

diagram (13)



- hexagon bolt with full screw M12X35
- flat washer C grade $\Phi 12$
- hexagon nut M12

diagram (14)



- Grade A Type I Hexagon nut with coarse screw M20
- Standard spring washer 20
- Flat washer C grade
- Hexagon head bolt with full and coarse screw M20X50(4/side)
- Hexagon head bolt with full and coarse screw M20X110 (3/side)

diagram (15)

4.4.4 Hang up the power pack. Fix the motor support plate on the power pack first, and then suspend it on the top of the column.

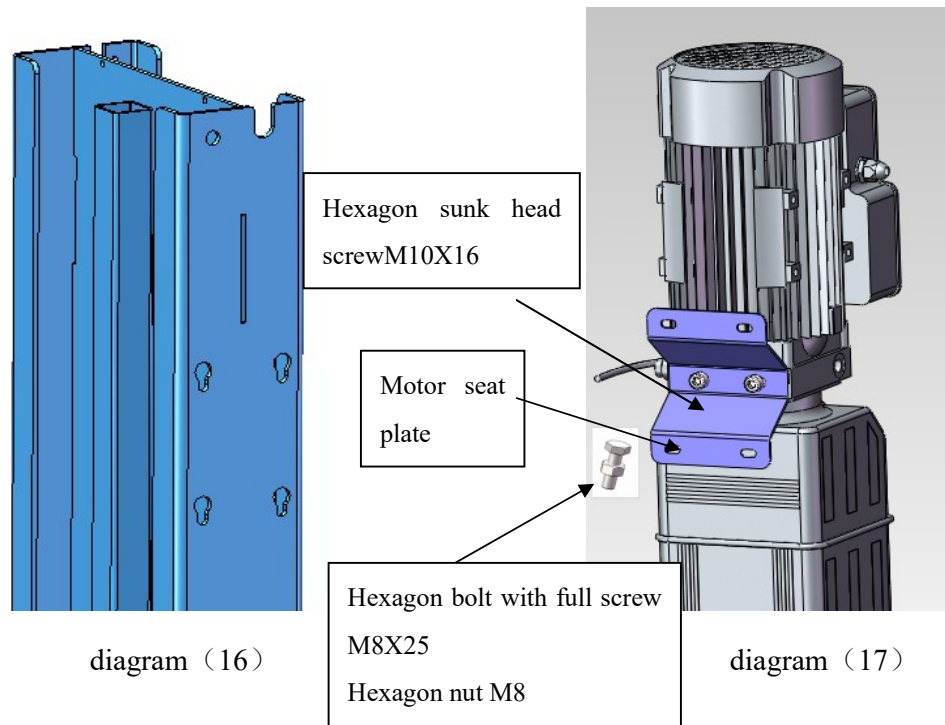

4.4.5 Connect the oil hose. Connect the oil hose 1 and the oil hose 2 with tee coupling. The Other end of the oil hose 2 connect the power pack.

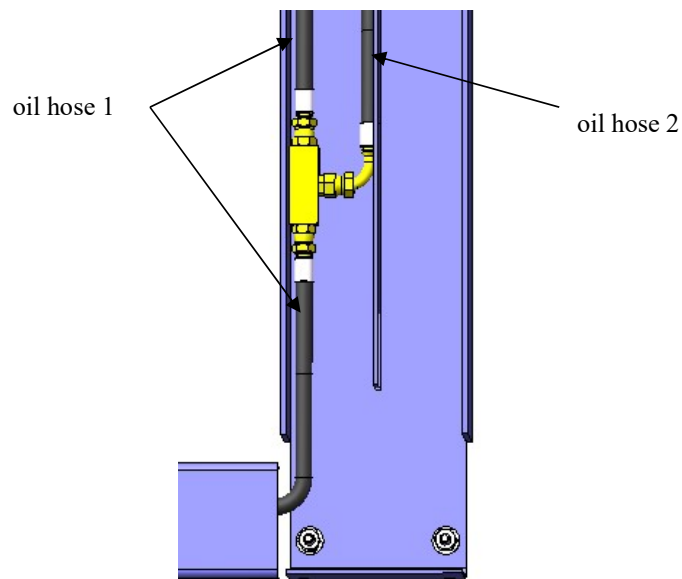

diagram (18) the connection of oil hose

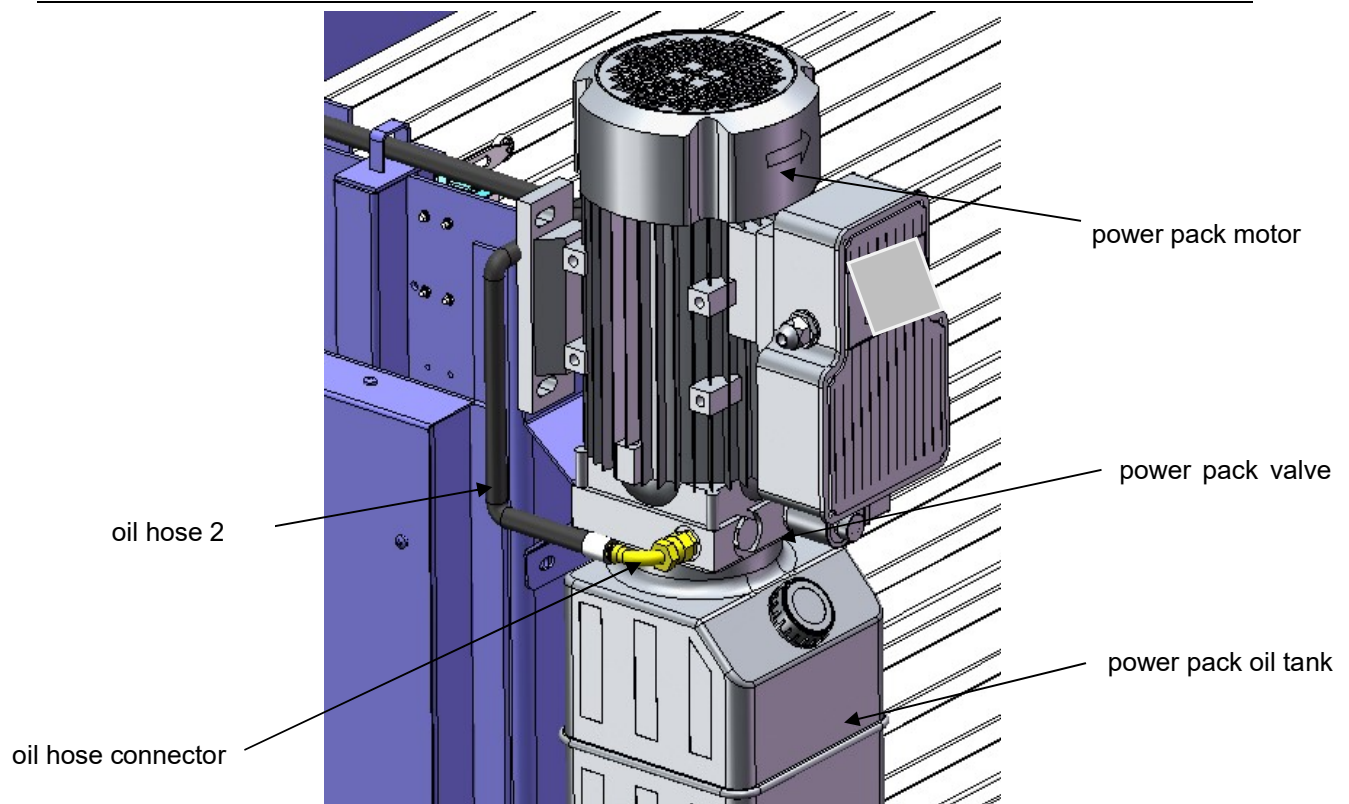

diagram (19) the connection between the oil hose and the power pack

4.4.6 Fix one end of the chain underneath the column, pull it out from the top of the chain pulley, pass through the opening of the platform, and pull it out from the other end of the platform opening.

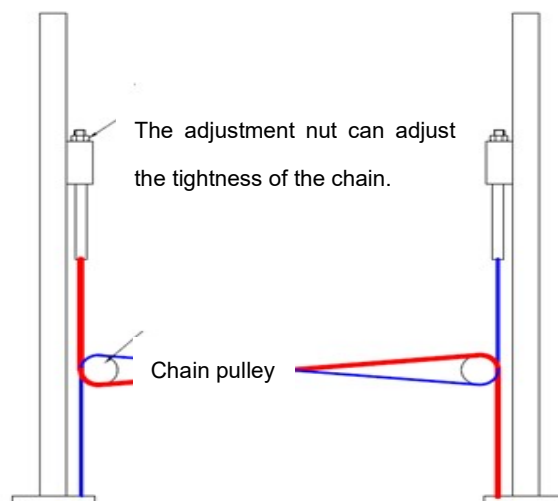

diagram (20)

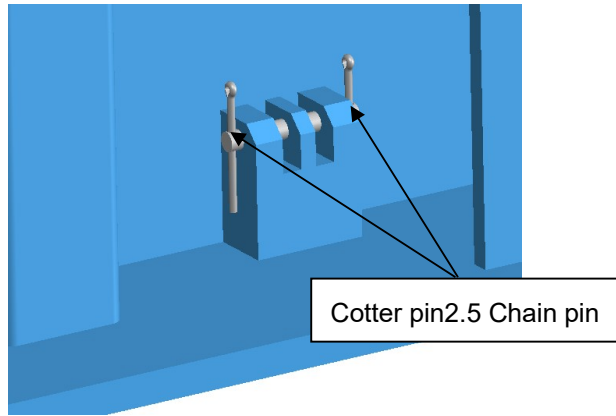
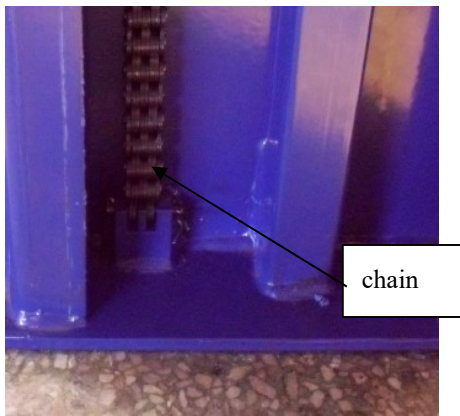
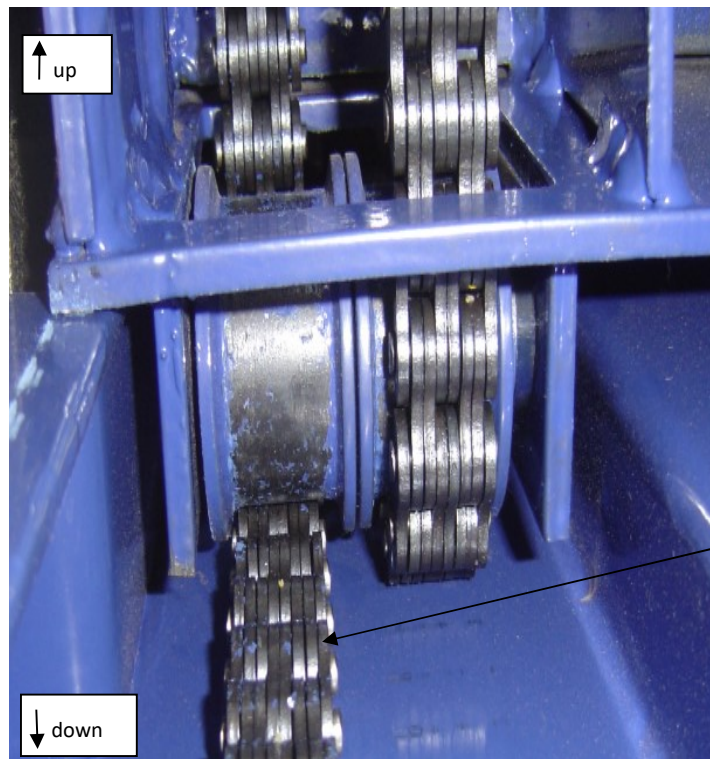

diagram (21)

diagram (22)



The chain pass through from bottom to top.

diagram (23)

4.4.7 pull the chain out from another carriage chain pulley and fix it on the chain fixed support on the top of the column.

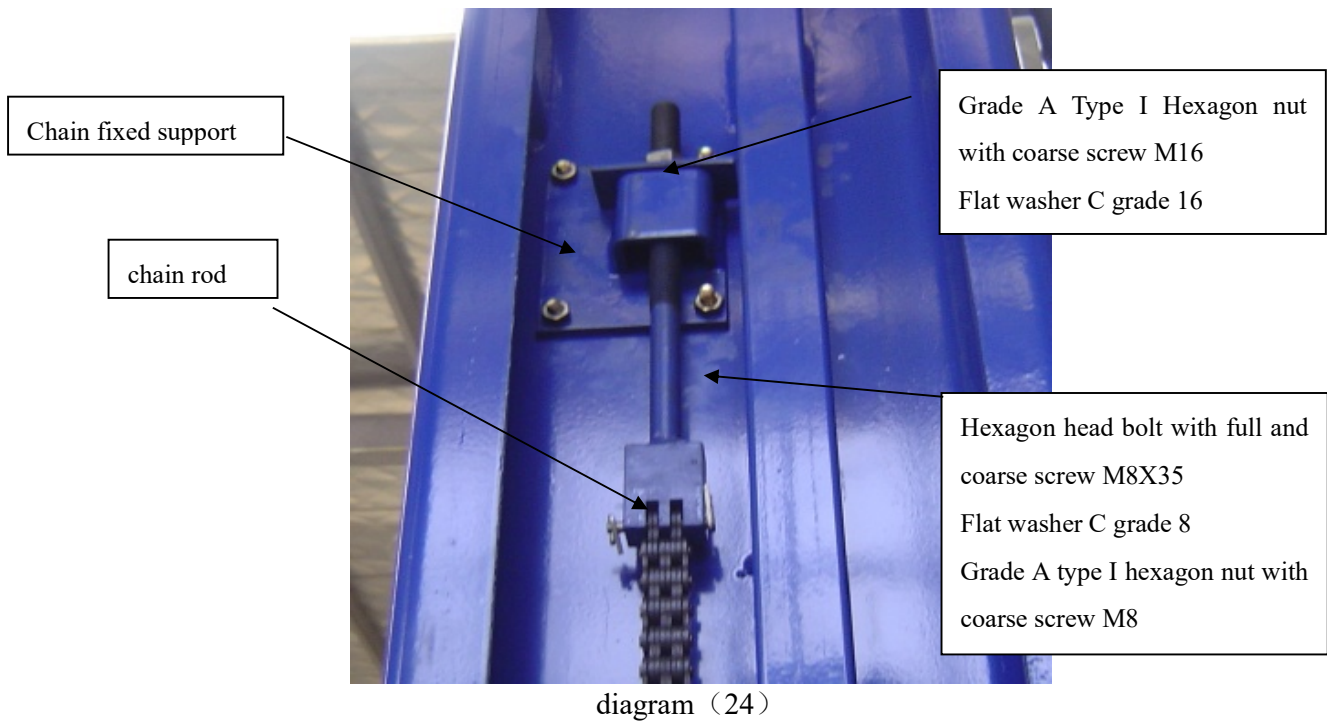

4.4.8 connect the locking device.

The live knot bearing, and the lock release pull rod connect the manual lock release device, the nut on the pull rod adjust the tightness of the pull rod.

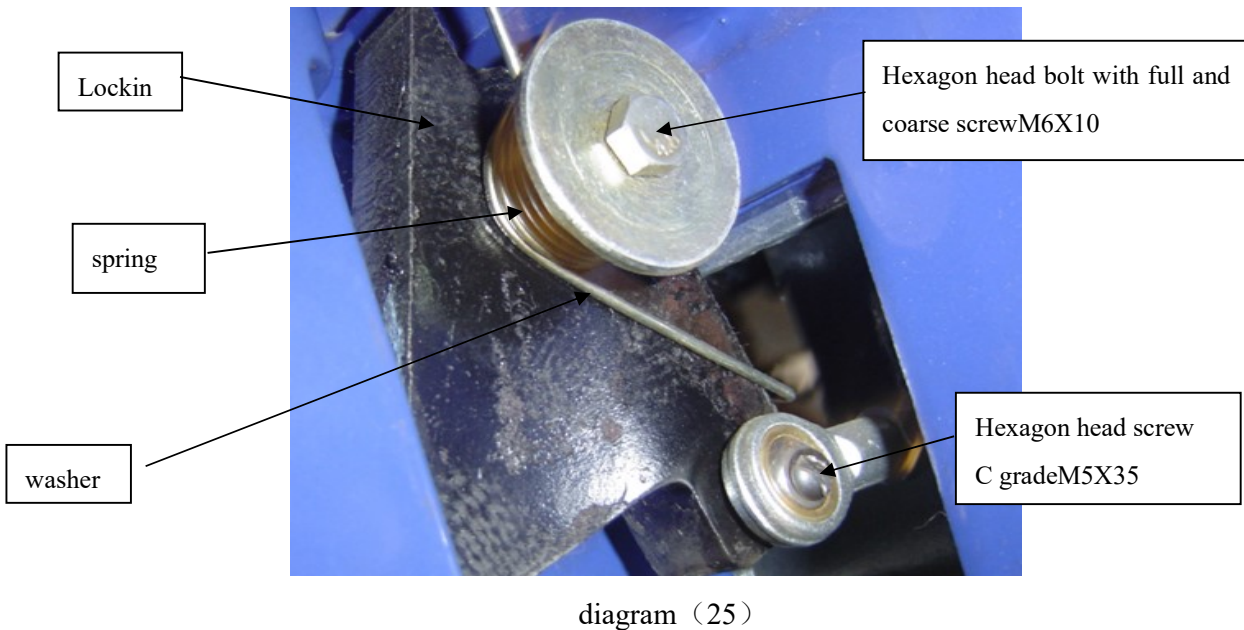

4.4.9 Add appropriate hydraulic oil into the power pack , connect the power, and then start the power pack, control the lift of the platform with dot move lift control button, stop lifting when the platform rise to the height about one meter, fixed all the bolts of carriage

and platform.

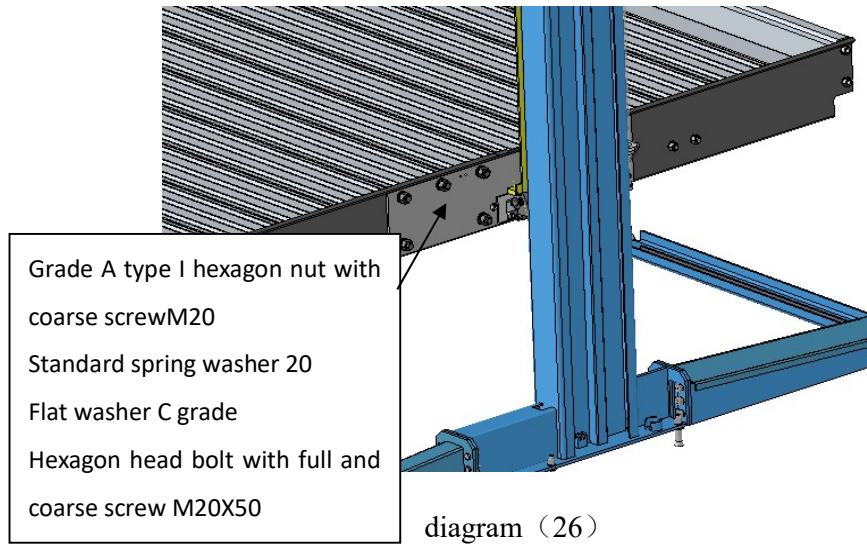

4.4.10 Install electromagnet

We have already assembled the electromagnet 、 spring and live knot bearing together before the delivery. The user should install the electromagnet according to the following diagram and connect the live knot bearing and unlock block on the carriage with bolt.

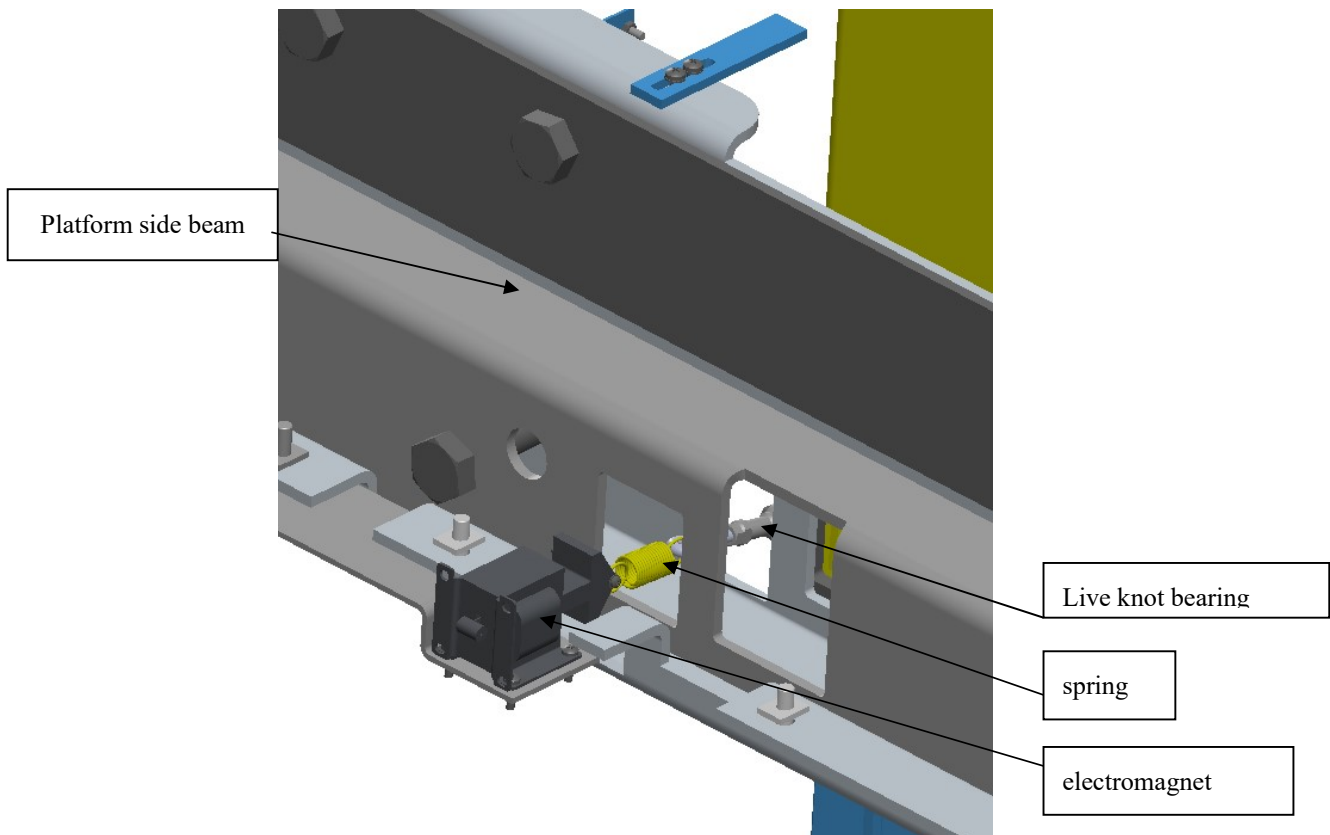

diagram (27) the view after hiding the wave plate

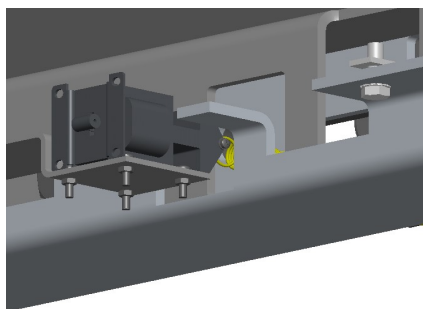

diagram (28) bottom view

4.4.11 Install optic sensor

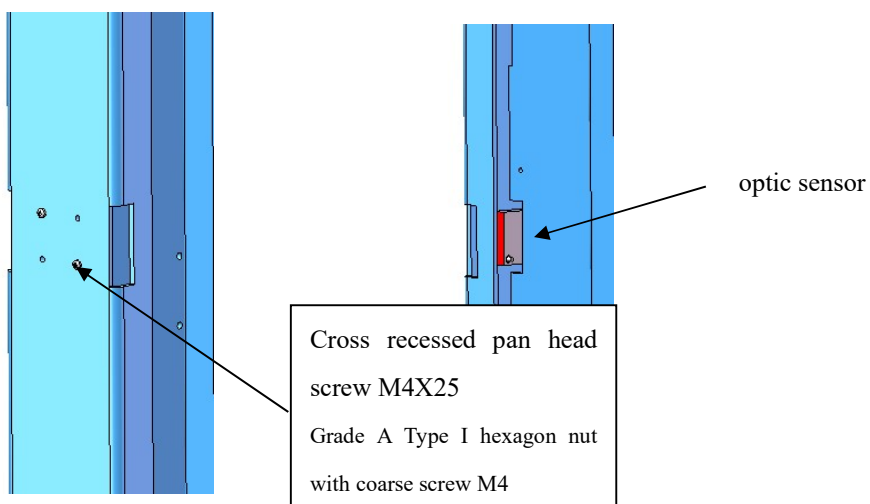

diagram (29)

4.4.12 Install upper limit switch

The customer can adjust the installation height according to the actual parking requirements of themselves.

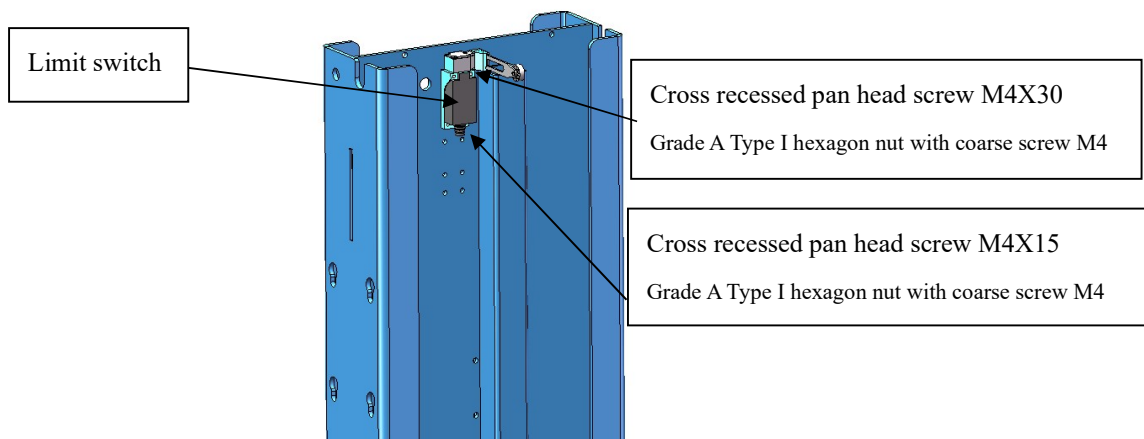

diagram (30)

4.4.13 Control arm installation and button box

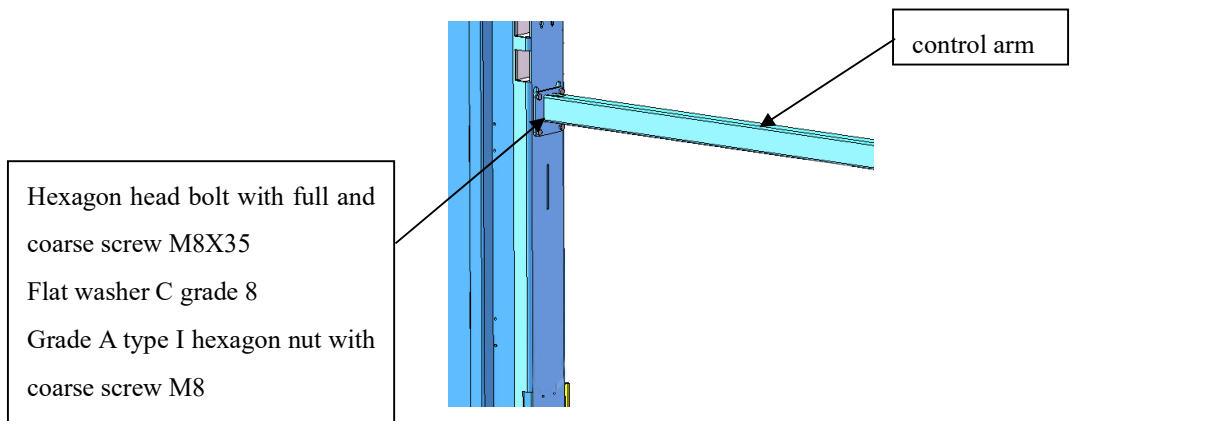

diagram (31)

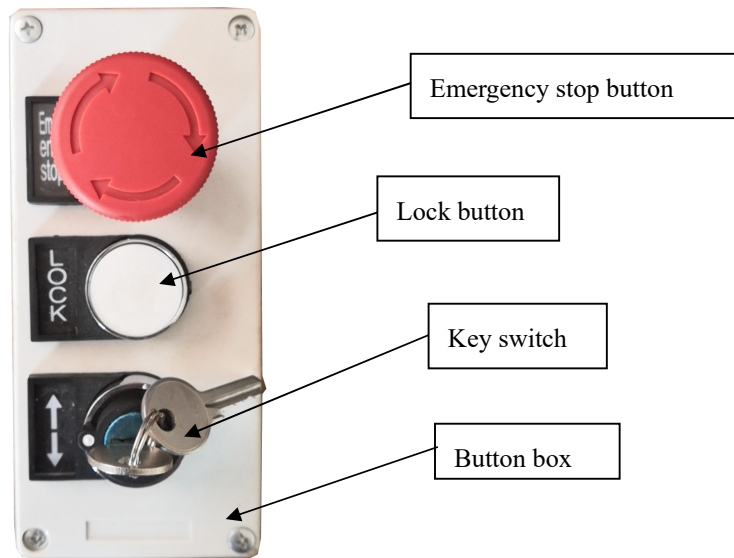

diagram (32)

4.4.14 Take base plate of post as a template to drill hole with electric hammer on the concrete ground. These holes should be about 120mm deep. Prohibit expanding the hole or shaking the hammer. After drilling hole, clear the inside of the hole and check the alignment of the base plate and chalk line.



diagram (33)

4.4.15 Hammer the stone bolt into the hole, until the washer touches the basement plate, if you want to underlay the U-type thin slice for the basement plate, set apart enough screw length.



diagram (34)

4.4.16 If the column is uneven with the ground, you need to insert U-type thin slice to adjust. After fixing the stone bolt, the column will be vertical to the ground.

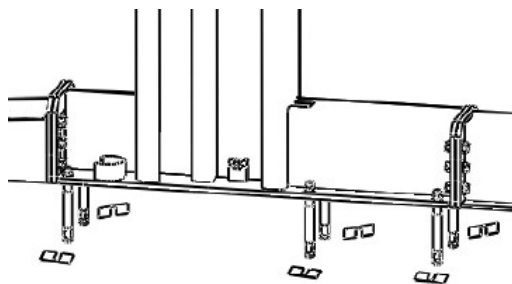

diagram (35)

4.4.17 Adjust the distance $A_1=B_1$ and $A=B$ between the two columns. Add the gasket to adjust when the distance is unequal ($A_1 > B_1$). After the column is vertical to the ground, screw down the stone bolt and nut.

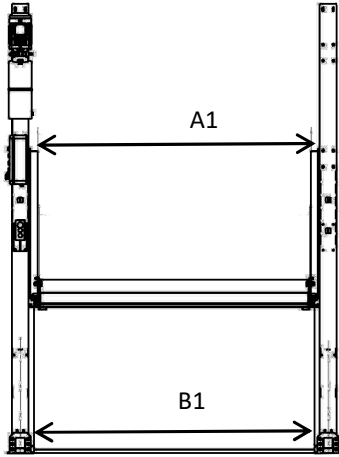

diagram (36)

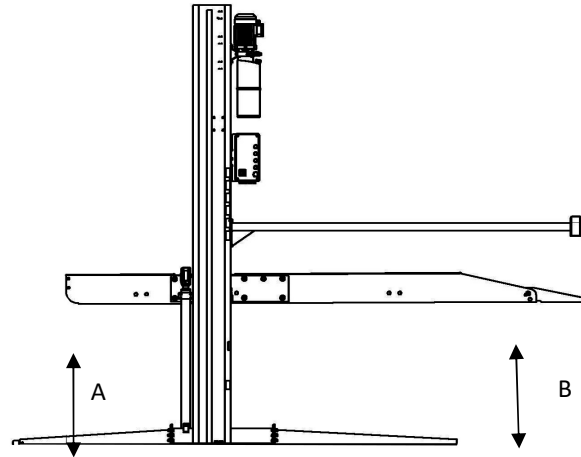

diagram (37)

4.4.18 Fix the chain, the tightness should be moderate, adjust the column of two sides to make them parallel.

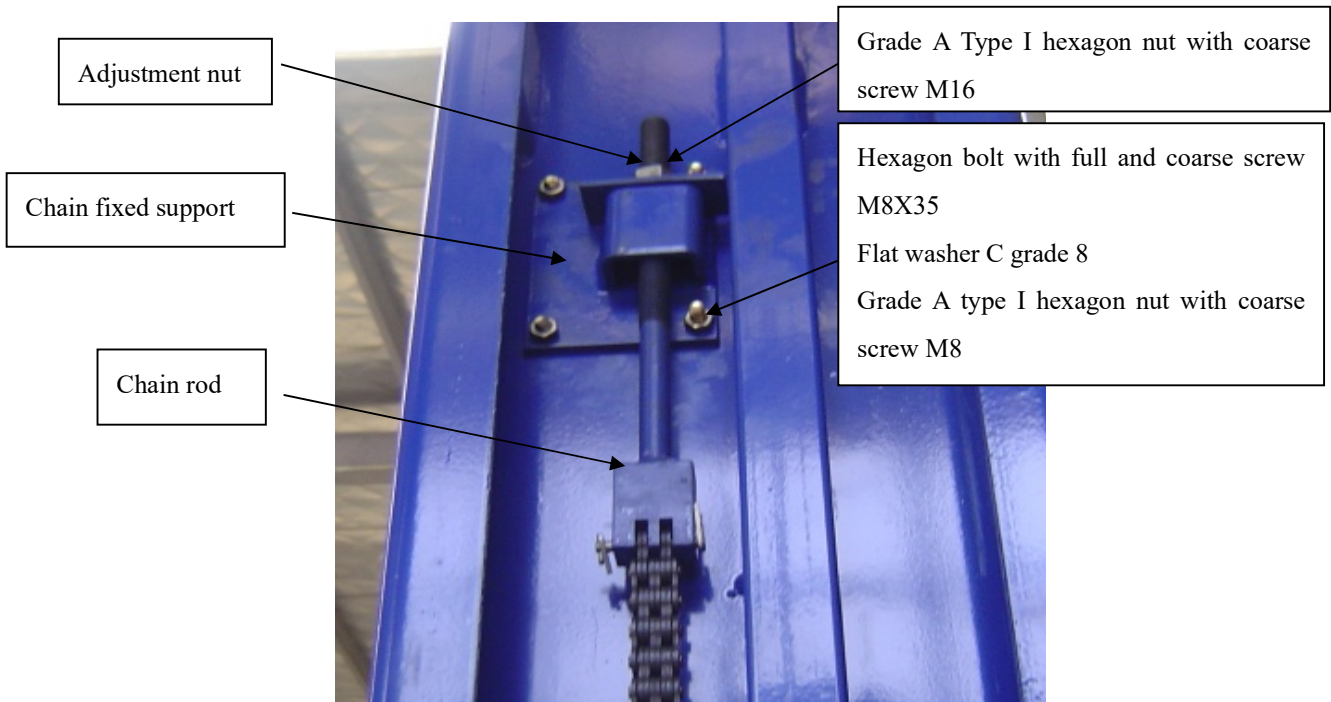

diagram (38)

4.4.19 Rotate the key switch on the control box, the lift rise, the cylinder begins to work, there will be crawl phenomenon.

4.4.20 when the lift rise to the highest position, stop rotating the key switch, to avoid the damage to the cylinder.

4.4.21 If you want to lower down, you should let it rise some distance, (about 10-20mm), and then unlock manually. Then rotate the key switch in an opposite direction, lower the lifting height to half.

Then manual lock release. Then rotate the key switch in opposite direction to lower the lifting height to half. (attention: you can loose the lock release when the lock release block lowered to position under the lock release hole)

4.4.22 At this time, loosen the exhaust bolt on the top of the cylinder, don't loosen it completely, screw it down after exhausting the air.

4.4.23 Then continue to rotate the key switch, lower down the lift with safety. And then repeat to lower it down several times, discharge the air in the cylinder. (Attention during the whole lifting process, observe all the operation parts, check the correctness of the installation and the debugging, only when you confirm that there is not any mistakes finally can you start the lift.)

4.4.24 After the installation and the debugging, lubricate each sliding part with the lubricant (supramoly).

5.The introduction of the control system

5.1 Control theory

There is a limit switch on the top of the device, to control the limit height of the platform when move up, customer can adjust the installation position of the limit switch according to the actual parking requirement and site space. The difference in height of adjacent installation position is 56mm.

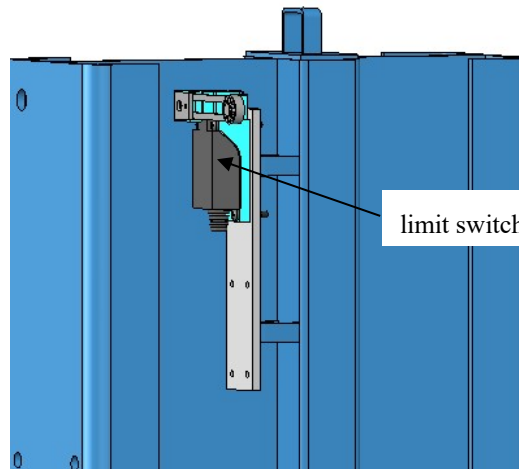

diagram (39)

The lift of the platform can be controlled by dot move. The operator can control the lift of the platform with dot move key switch, and then conduct the vernier regulation of the lifting height according to the actual parking requirement.

When picking up the car, you should rotate the key switch to let the car rise for some distance (about 10-20mm), and then pull the lock release handle to release the locking, and then rotate the key switch in the opposite direction to lower it down.

Besides the key switch on the button box of the control arm in front of the device, there is an emergency stop switch, you should press down the button under emergency situation, to power down the device. But after excluding the fault, rotate the button to reset it, or the device still can't run.

5.2 Control matters need attention

When assembling, confirm the fastness of the wiring; check if there is any visible wire end to

avoid short circuit.

When handling the equipment or parts, take measures to avoid breaking the line, otherwise, it will cause a short circuit.

If a short circuit occurs, the fuse protector will take effect. After that, the fuse should be changed.

The failure of the control system should be maintained by professional technicians. It is forbidden for the staff without electric service-related knowledge to repair the device, to avoid body damage caused by electric shock or device damage caused by wrong wiring.

Prohibit exposing electric elements in damp environment to avoid short circuit.

5.3 Parts of control problem

phenomenon	Possible reason	Exclusion methods
There is no reaction when rotate the key switch.	The fuse of control circuit is burned.	Check and change the burned fuse.
	The power cord is open circuit.	Check the wire circuit to confirm the wire connection is right.
	The emergency stop switch is pressed down.	Rotate the emergency stop switch to reset it.
The platform can't rise when rotate the key switch but can be lowered down when rotate it in opposite direction.	The platform has been in the highest position.	Normal phenomenon.
	Wiring of limit switch is in bad condition.	Check the circuit of limit switch to guarantee good connection.

6. Device usage

6.1 Attention item

6.1.1 If the equipment will be not in service for a long time, the main power supply should be closed to avoid accidents and to save energy.

6.1.2 If the equipment has not been in service for a long time, please lubricate it and check if there is any damage and rust corrosion before using it again. Check if the equipment is in good condition through no-load running.

6.1.3 Do not use the equipment if the floor or any component is damaged.

6.1.4 Do not operate the equipment if there is a person or other obstacle under it.

6.1.5 Prohibit using the equipment for other purposes.

6.1.6 Safety lock device should be in good condition at any time.

6.1.7 Do not let the unlocked equipment in a certain height, and leave.

6.1.8 Keep the motor dry. We are not responsible for the motor damage caused by damp.

6.1.9 Warning mark:



There should be enough space to escape if the vehicle is at the risk of falling down.



The gravity center of vehicle should be in the center of platform.



There should be enough space to place the lift when lifting and lowering the vehicle.



Avoid excessive shaking when there is vehicle on the lift.



Don't exceed the closed height of the lift control.



Avoid damage of the foot when lowering the lift.

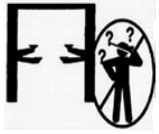

The lift can only be used by the trained operator.



Only the staff authorized can stay on the lift site.



When moving and assembling the medium parts, safety bracket should be used.

6.2 Parking

6.2.1 Drive the car on the appropriate position of the platform. Avoid collision with the control cabinet and the rear of the platform.

6.2.2 Start the manual brake after the car on the position.

6.2.3 Open the car door carefully to avoid any collision with the car door.

6.2.4 The driver leaves the drive cabin.

6.2.5 Press the up button, lift the car to the appropriate position, and lock the lift.

Take notice that the safety locking device should always be valid.

6.2.6 You can park other vehicles under the platform, but before parking, check and confirm that all the vehicle height of the parked vehicle should be no more than platform height, to avoid the vehicle being scratched.

6.3 Take the car

6.3.1 Be sure there is no person or obstacle under the car, if there is car parked under the platform, drive the car away from the device, to ensure not affect platform come down and pick up the car.

6.3.2 Firstly, press the up button to lift the cylinder, to separate the locking block. And then press down button, to lower the platform to the ground.

6.3.3 The driver enters the operator cabin.

6.3.4 Drive the car off the platform.

7.maintenance and service of device

7.1 Overhaul

Conduct the maintenance every month regularly to ensure the use safety of the device and prolong the use life.

1. Check if the carriage can work normally.
2. Check if the chain and its connector, chain pin shaft, cotter pin can work normally.
3. Check if the expansion bolt is loose. You should tighten the expansion bolt if it is loose.

4. Check whether the locking device can work normally, if the work of it is abnormal, find out the reason and exclude the fault.

5. Check if there is any distortion of the column. Check is the column is vertical to the ground. You should stop operating the device if there is any serious distortion of the column caused by overload and abnormal use.

6. Add the grease on the slide block that is in the column.

7.2 Common fault and repair method

phenomenon	Possible reason	Exclude method
The motor works, no hydraulic leakage, the sound is abnormal, but the platform can't rise.	There is air in the hydraulic oil.	Lift with idle load to the highest position, and keep for seconds and then lower down, when lowered to the half-height, screw to open the oil hose connector, discharge the air and then screw down.
	the hydraulic oil solidifies, or viscosity of the hydraulic oil is too big as surrounding temperature is too low.	discharge the hydraulic oil, refilling qualified hydraulic oil.
	The load is overweight.	Check and confirm that lift weight is less than rated load.
Hydraulic oil leakage of oil hose connector.	The connector is loose.	Screw down the tube connector.
	The connector is damaged.	Change the connector.
Hydraulic leakage of the cylinder.	The hydraulic seal kit is damaged.	Change the seal kit or cylinder.
Motor do not work.	The motor is burned.	Change the motor after check and confirm that the power is correct.
	The voltage is too low.	Check and confirm that the voltage is the regulated voltage.
	The fuse is burned.	Change the fuse.
	The limit switch is damaged.	Change the limit switch.
Platform can't fall down.	The platform is locked.	Control the platform lift, after lock release lower the platform down.
Platform can't fall down.	The hydraulic oil viscosity is too big.	Change to the regulated hydraulic oil or consult local hydraulic manufacture.
	The plug valve of the power unit is jammed.	take apart the valve part to wash (pay attention to dust proofing)
	The oil hose or the hose connector is jammed.	Dredge the oil hose and hose connector.
Motor rotates reversely	Wrong wiring	Rewiring according to the circuit drawing

Attachment one: basement drawing

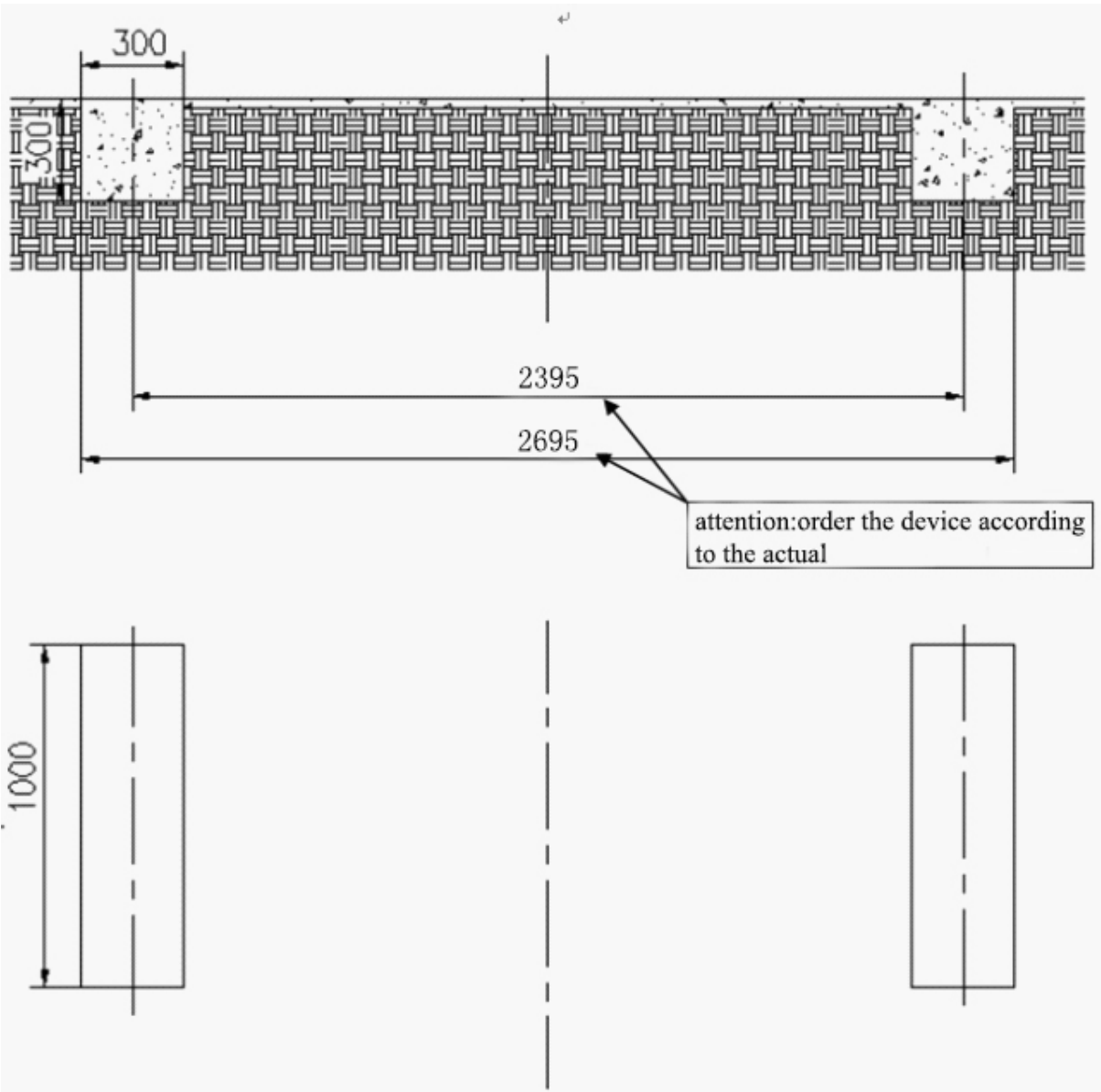

Attachment two: electrical diagrams

