



CHAMPION DISTRIBUTORS LLC

INSTALLATION MANUAL & OPERATION INSTRUCTIONS

TP10F





WARNING

- This instruction manual is an essential integral part of this product. Please read all instructions.
- Properly keep this manual for use during the maintenance.
- This equipment is only used for its clearly designed purpose, and never use it for other purposes.
- The manufacturer is not responsible for any damage caused by improper use or other purposes of use.

PRECAUTION

- Only the qualified personnel having undergone special training can operate this machine. Without the permission of the manufacturer or not following the requirement of the manual, any changes in the machine part and in the usage scope may cause direct or indirect damage to the machine.
- Don't keep the lift in the extreme temperature and humidity environment. Avoid installation beside the heating equipment, water tap, air humidifier or stove.
- Prevent the lift from contacting large amount of dust, ammonia, alcohol, thinner or spray adhesive, and prevent it from rain shower.
- During the machine operation, non-operators should be kept away from the machine.
- Inspect machine daily, do not use lift with damaged parts or being damaged. Use original components to replace damaged parts
- The lift can't be over loaded. The rated load of the lift is already marked on the nameplate.
- Please don't raise the lift when there are people in the vehicle. During the operation, the customer and spectators shouldn't stand in the lifting area.
- Keep the lifting area free from obstacle, grease, machine oil, garbage and other impurities.
- Position the swing arm of the lift, making it contact the lifting point as recommended by the manufacturer. Raise the carriage and confirm the lifting pad and vehicle are closely contacted. Raise the carriage to the appropriate working height.
- For some vehicles, the parts dismantling (or installation) will cause severe deviation of the center of gravity, leading to unstable vehicle. The support is needed to keep the balance of the vehicle.
- Before moving the vehicle away from the lifting area, please position the swing arm and lifting pad back away to avoid blockage during the movement.
- Use appropriate equipment and tools as well as safety protection facilities, e.g. working uniform, safety boot, etc.
- Pay special attention various safety marks attached to the machine body.
- Keep hair, loose clothing, fingers, and all parts of body away from moving parts.
- Pay special attention not to dismantling the safety unit of the machine or making it not functioning.
- The hydraulic oil used for this lift is N32 or N46. Please refer the safety data of grease and oil shown in the manual.
- Let components cool down before storage, loosen component cables completely in storage.
- Do not install lift in the open air or expose to rain, special requirements should be offered to manufacturer if it can't be avoided.
- Carefully check equipment list before installation. Immediately connect distributor or Launch for any question.

Caution Labeling Exemplification













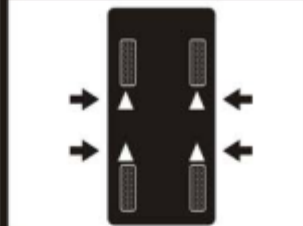

<p>! WARNING</p>  <p>Clear area if vehicle is in danger of falling.</p>	<p>! WARNING</p>  <p>Position vehicle with center of gravity midway between adapters.</p>	<p>! CAUTION</p>  <p>Use vehicle manufacturer's lift points.</p>	<p>! CAUTION</p>  <p>Always use safety stands when removing or installing heavy components.</p>
<p>! WARNING</p>  <p>Remain clear of lift when raising or lowering vehicle.</p>	<p>! WARNING</p>  <p>Avoid excessive rocking of vehicle while on lift.</p>	<p>! CAUTION</p>  <p>Use height extenders when necessary to ensure good contact.</p>	<p>! CAUTION</p>  <p>Auxiliary adapters may reduce load capacity.</p>
<p>! WARNING</p>  <p>Do not override self-closing lift controls.</p>	<p>! WARNING</p>  <p>Keep feet clear of lift while lowering.</p>	<p>SAFETY INSTRUCTIONS</p>  <p>Read operating and safety manuals before using lift.</p>	<p>SAFETY INSTRUCTIONS</p>  <p>Proper maintenance and inspection is necessary for safe operation.</p>
<p>! CAUTION</p> 	<p>! CAUTION</p> 	<p>SAFETY INSTRUCTIONS</p> 	<p>The messages and pictographs shown are generic in nature and are meant to generally represent hazards common to all automotive lift regardless of specific style.</p>

TABLE OF CONTENTS

1. Outline	5
1.1 Model Description	5
1.2 Purpose	5
1.3 Functions and Features	5
1.4 Technical Specifications	5
1.5 Environmental Requirement	6
2. Lift Structure.....	6
2.1 Lift structures are shown as below :	6
2.2 Main structure principles:	8
3. Operation Description	8
3.1 Precautions for vehicle repair work	8
3.2 Preparation before operation	8
3.3 Inspection before operation	9

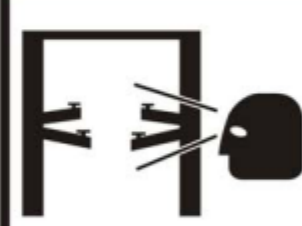
3.4 Lifting the Vehicle.....	9
3.5 Lowering the Vehicle	9
3.6 Manual emergency lowering	10
4. Hydraulic and Electrical System of the Equipment.....	10
4.1 Hydraulic System of the Lift	10
5.Solutions to FAQ.....	12
6. Repair and Maintenance	13
7. Storage and Scrap.....	15
7.1 Storage.....	15
7.2 Scrap.....	15
8. Tools for Installation and Adjustment	16
9. Unpacking.....	16
10.Installation.....	16
10.1 Important notice.....	16
10.2 Installation Procedure	17
11. Lift Adjustment.....	24
11.1 Preparation before the adjustment	24
11.2 Adjustment procedure ^[1] _[SEP]	24
DECLARATION OF WARRANTY AND LIMITATION OF LIABILITY	25
TO THE READER	25
WARRANTY CERTIFICATE.....	25
TECHNICAL SERVICING.....	25

1. Outline

1.1 Model Description

Model	Description
Floor Plate Lift	9000lb,Symmetric 2-postlift with base frame (Fig.1)
Clear Floor Lift	9000lb,Symmetric 2-postlift with cross beam (Fig.2)

1.2 Purpose

This machine is applicable for the lifting of various small and medium-sized vehicles with total weight below 9000lb in garage and workshop.

1.3 Functions and Features

- The cable and oil pipe are fully concealed, with decent and elegant appearance.
- Designed based on the international standard, meeting the demand of the garage and workshop.
- Top limit switch, effectively protecting the vehicle from overhead collision.
- Dual hydraulic cylinders drive, stable lifting and lowering.
- Manual lowering, safe and simple in operation.
- Adopt two steel cables for equalization, force two carriages to move synchronously, and effectively prevent the vehicle

from tilting.

- Lowest height of lifting pad is 100mm, good for repairing low chassis or low profile car.

1.4 Technical Specifications

Noise: Working noise: ≤ 75 dB (A) **Power unit:**

Electrical parameters of the machine : Motor (optional)

Voltage : According to client's requirement

Single phase: 110V/60Hz 2.2kW, 220V/50Hz 2.2 kW, 220V/60Hz 2.2 kW

Three phase 380v/50Hz 2.2 kW

Basic parameters of the equipment:

Model	Rated load	Lifting.H.	Rising time	Passing width	Machine width	Machine height	Packing size
Floor Plate Lift	9000lb	1820mm	≤ 50 s	2520m	3410mm	2860mm	2880×470×740mm
Clear Floor Lift	9000lb	1820mm	≤ 50 s	2520m	3410mm	3720mm	2880×470×740mm

1.5 Environmental Requirement

Working temperature : $-5^{\circ}\text{C} \sim +40^{\circ}\text{C}$

Relative humidity: Temperature $+30^{\circ}\text{C}$, relative humidity 80%

Transport/storage temperature : $-5^{\circ}\text{C} \sim +40^{\circ}\text{C}$

Height above sea level : No more than 2000m

2. Lift Structure

2.1 Lift structures are shown as below :

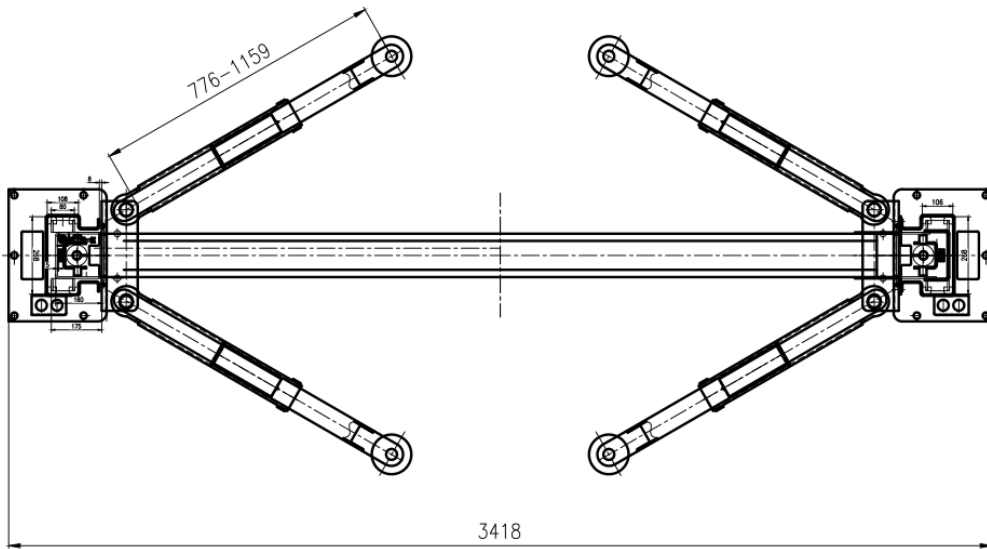
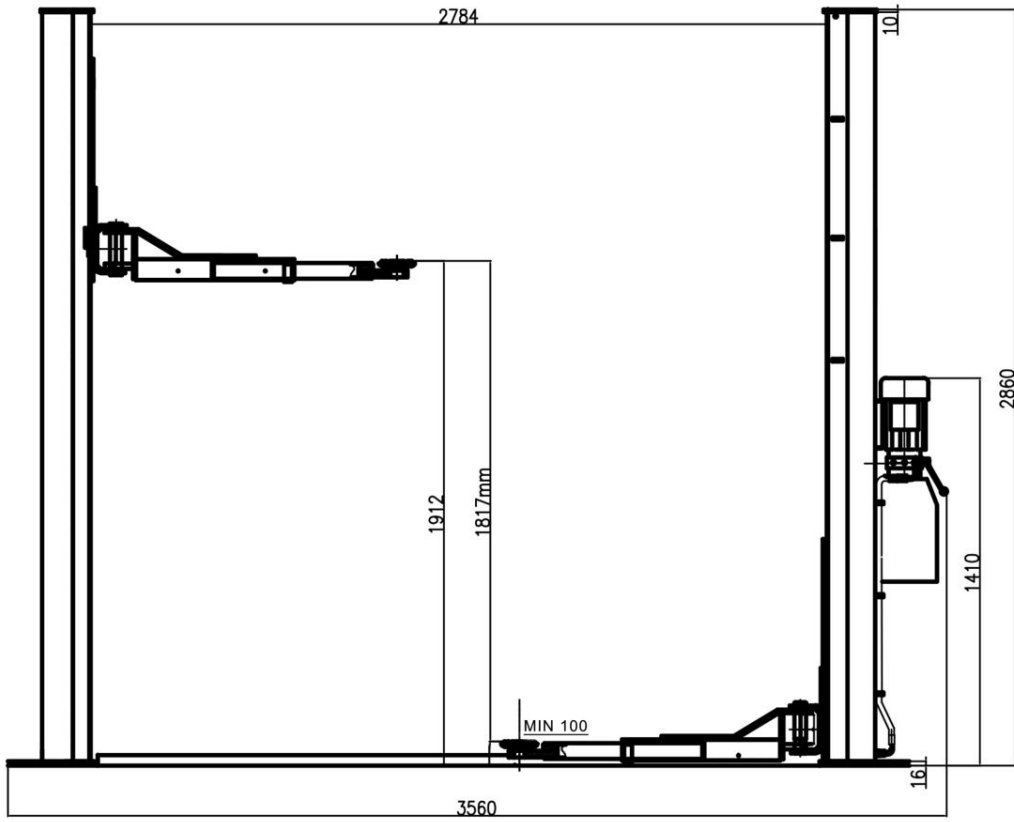
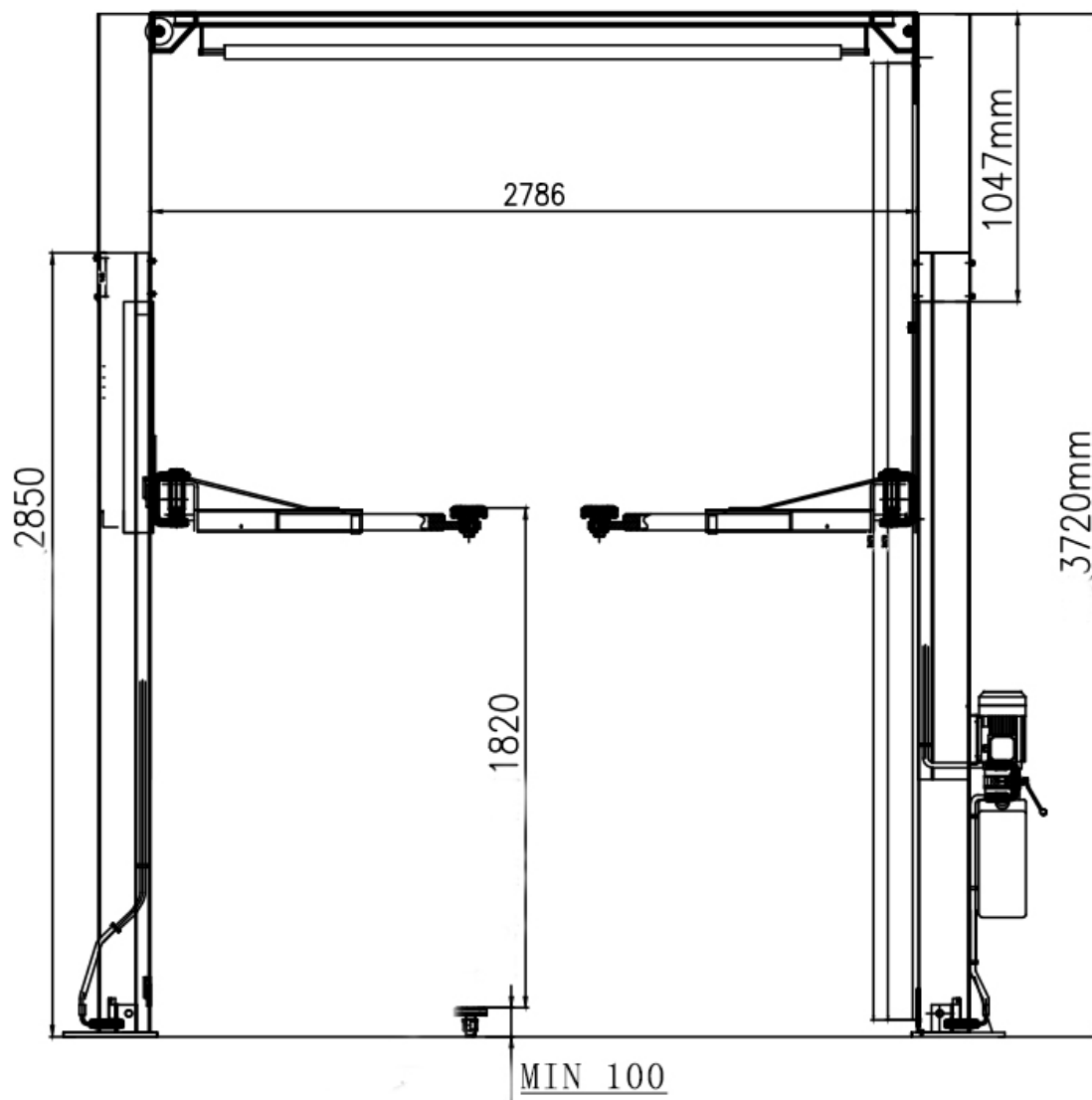

Fig.1



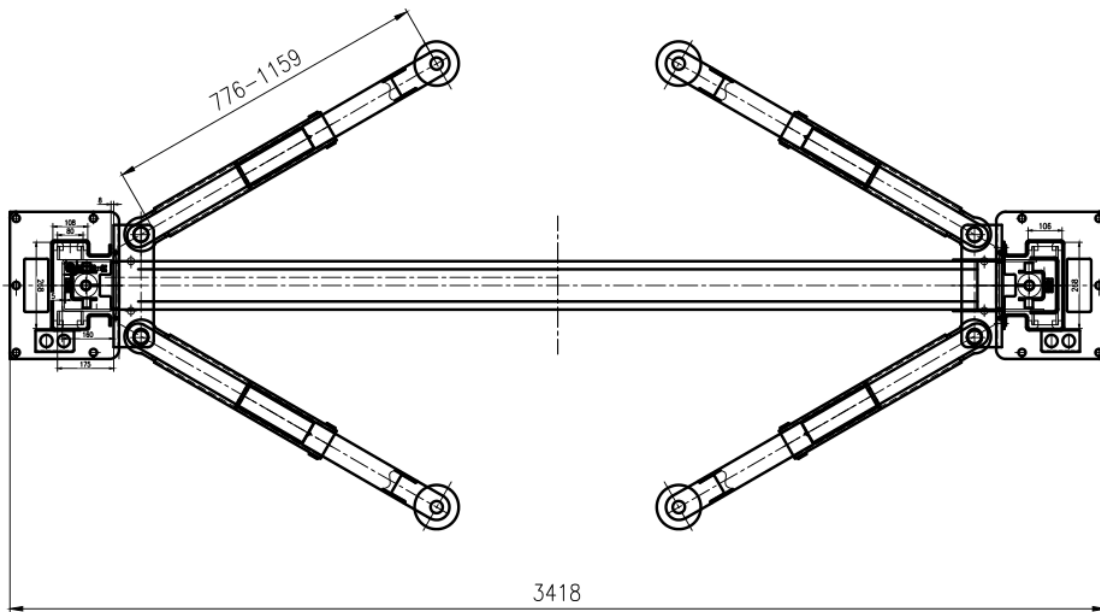

Fig.2

2.2 Main structure principles:

- Lifting mechanism: Each column is installed with a hydraulic cylinder, when hydraulic oil is pressed from power pack into the lower chamber of main cylinder, piston rod moves upwards to drive the upward movement of carriage through leaf chain.
- Load supporting mechanism : When vehicle drives into the working area, adjust the angle and telescopic length of arms to make lifting pads at an effective load supporting position that contact with vehicle, then adjust the lower screw 's height of lifting pad to make it applicable for vehicles with different chassis.
- Balance mechanism : In order to keep machine balanced during lifting and lowering, two carriages are interconnected and forced to move synchronously by two wire ropes. If the right and left carriages and arms are not at the same level, adjust the end nut of wire rope and pull wire ropes tight to make arms leveled.
- Manual safety locking system: the safety locking plates are installed on the two carriages and the toothed bar plate is welded on the internal wall of the column. During the lifting of the carriage, the safety locking plate goes up against on the toothed bar plate by the tension of spring. When the carriage stops, the safety locking plate opens and then is engaged in the toothed bar slot to ensure the carriage will not go down; when the lowering operation is required, just raise the carriage upward a little to loosen the safety locking plate from the toothed bar slot, and then manually pull the steel wire rope so as to jack up the safety locking plate by sliding plate, so the safety locking is released so that the carriage can be lowered down. Because the manual safety locking systems are installed on the two carriages, double safety protection can be provided; therefore, to disengage the safety locking, the steel rope on the two carriages shall be respectively pulled. To prevent the vehicle slip, the swing arm is installed with positioning mechanism, making the swing arm capable of automatic locking during operation.
- Safety lock scope: Safety lock mechanism is effective when the front end of carriage is between 450mm and 1820mm high above the ground.

3. Operation Description

3.1 Precautions for vehicle repair work

- Different vehicles have different center of gravity positions. First understand the position of center of gravity, and when the vehicle enters into the lift, make its center of gravity close to the plane formed by two columns. Adjust the swing arm, and make the lifting pad support onto the lifting point of the vehicle.
- For vehicle lift with top beam ,pay attention to the car roof position observation in order to avoid accident during lifting.
- Carefully read the warning symbol.
- The hydraulic valves have been adjusted before ex-factory, and the user can't make self-adjustment, otherwise it will be responsible for all the consequences generated.

- Based on the production needs, some specifications in the instruction manual are subjected to change without notice.

3.2 Preparation before operation

- Lubricate contact surface of the carriage with general-purpose lithium grease (GB7324-87).
- All sliding surface should be coated evenly from the top to bottom.
- Fill hydraulic oil N32 or N46 to the oil reservoir of the power unit.

3.3 Inspection before operation

- **Check to see if the motor power is installed properly.**
- **Check to see if all the connection bolts are fastened.**



Note: Don't operate the lift with damaged cables or damaged and missing part, until it is inspected and repaired by the professionals.

3.4 Lifting the Vehicle

- Keep work area clean, don't operate the lift in cluttered work area.
- Lower the carriage to the lowest position.
- Reduce the swing arm to the minimum length.
- Swing the arm along the route of the vehicle
- Move the vehicle to the location between the two columns
- Swing the arm and put the lifting pad below the recommended lifting point, and adjust the height of lifting pad to touch lifting point of vehicle

Press the UP button on the Power unit, slowly lift the vehicle to ensure the load balance, and then raise the lift to the required height.

- Release the UP button to engage the safety lock of carriage. At this time, the vehicle can be repaired.



Note:

- *Before operation, the safety locking devices must be Inspected.1) The gear blocks of the arm end must engage the gear block of the restraint shaft.2)No broken strand in the steel cable. 3)No deformation in the arm pad.*
- *When lifting the vehicle, all the swing arms must be used.*
- *Before lifting the vehicle, check all the hydraulic hose and fittings for oil leakage. In case of leakage, please don't use the lift. Remove the fitting with leakage and re-seal. Re-install the fitting and check if oil leakage still exists.*
- *After the vehicle is lifted, when adding or removing any major heavy object, use jack stand to maintain the balance of the vehicle.*

3.5 Lowering the Vehicle

- Clean the work area before lowering the vehicle.
- First press the start button to rise the vehicle a little, then pull two steel ropes on two carriages to disengage the safety lock.
- Press the lowering handle to lower the vehicle.
- Lower the vehicle till the swing arm down to the bottom and the lifting pads leave the vehicle chassis, and then release the lowering handle.
- The swing arms under the vehicle must be fully shrunk.

3.6 Manual emergency lowering

- In case of no electric power or power unit failure, lower the loaded vehicle manually to its initial position as follows:
- Padlock the power switch;
- If the mechanical safeties are engaged, raise the lift a little by using a hydraulic jack or the emergency hand pump (optional), then pull two steel ropes on two carriages to disengage the safety lock.
- Press the lowering handle to lower the vehicle.



Note: When the lift doesn't work, you must switch off the power.

4. Hydraulic and Electrical System of the Equipment

4.1 Hydraulic System of the Lift

Diagram of the hydraulic system

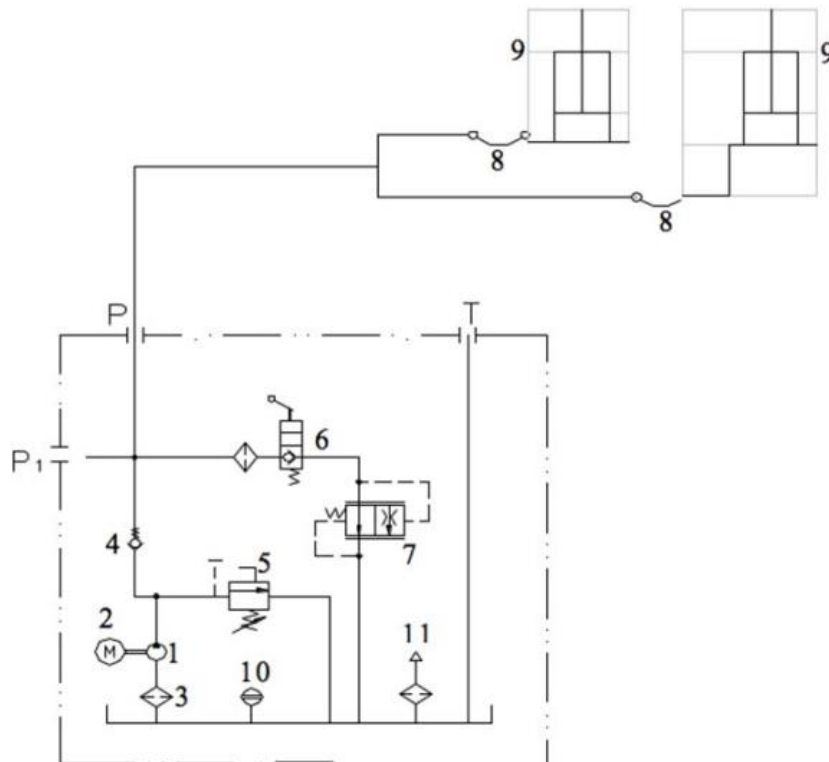

Fig.3

1- Gear pump, 2-Motor, 3-Oil filter, 4- Check-valve, 5- Safety valve, 6- Lowering handle valve,
7- Servo flow-control valve, 8- Hose, 9- Hydraulic cylinder, 10- Level gauge, 11- Air filter

The working principle of the hydraulic system is as follows:

As shown in Fig.2, when the start button is pressed, the motor 2 is started, driving the oil pump 1, sucking the hydraulic oil from the oil tank into the oil cylinder9, forcing the piston rod move. At this time, the safety valve5 is closed.(the Max working pressure is already adjusted before exfactory. The safety valve can ensure the capacity of the rated load, but when the pressure in the system exceeds the limit, automatically overflow will be happened inside safety valve to protect the hydraulic system).

Release the start button to stop the oil supply and the lifting will stop. For lowering, first start Motor 2 to raise vehicle a little, pull the steel ropes on two carriages to release the safety lock mechanism, then press the lowering handle, the valve 6 is actuated, the hydraulic oil flows back and the lift starts lowering.

4.2 Electrical System of the Lift

Diagram of electrical system for single phase motor

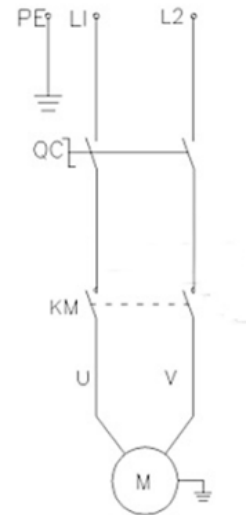

M1-Motor KM-Contactor SB –Button SQ- Limit switch

Fig.4

Diagram of electrical system for three phase motor

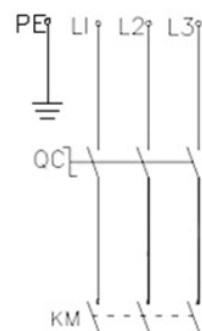

M1-Motor KM-Contactor SB –Button SQ- Limit switch

Fig.5

The electrical working principle is as follows:

Press the start button (SB) ,and the contactor (KM) will be powered; motor (M) is energized to drive the gear pump supplying oil to push the carriage upward; release the start button, and the contactor (KM) is open, then the motor (M) will lose the power, so the carriage will stop rising. As for the cross beam lift, if the vehicle is lifted up to the top and contacts the limit switch on the top beam, the contactor (KM)) will open, then the motor (M) will lose the power, so that the carriage stops lifting. Emergency stop button to emergency power-off function.

5.Solutions to FAQ

Symptom	Reason	Solution
Motor not operation	<ul style="list-style-type: none"> ●Check the circuit breaker or thermal relay for tripping ●Check the voltage to the motor ●Check the electrical wiring ●Limit switch is failed Motor wire is burnt 	<ul style="list-style-type: none"> ●Close the switch of circuit breaker or press the blue reset key of thermal relay ●Supply correct voltage for motor ●Correctly wiring as electrical system diagram

		<ul style="list-style-type: none"> ●Replace the limit switch ●Replace the motor
Motor is running, but the lift can't be raised.	<ul style="list-style-type: none"> ●Motor rotation reversed ●Lowering valve body open. ●Hydraulic pump sucks the air ●Suction tube is separate from the hydraulic pump. ●Low oil level 	<ul style="list-style-type: none"> ●Change the motor rotating direction through changing wire connection. ●Repair or replace the lowering valve Body ●Fasten all the suction pipe fittings ●Replace the suction tube ●Add the oil into the oil tank
Motor is running, the lift can be raised without load, but the vehicle can't be raised	<ul style="list-style-type: none"> ●Motor is running under low voltage ●Impurities inside the lowering valve body ●Regulation pressure of safety valve is incorrect. ●Lift is overloaded 	<ul style="list-style-type: none"> ●Supply correct voltage to the motor ●Remove impurities from the lowering valve body. ●Adjust the safety valve ●Check the weight of the vehicle
The lift is lowering slowly without pressing the lowering handle	<ul style="list-style-type: none"> ●Impurities on the lowering valve body. ●External oil leakage 	<ul style="list-style-type: none"> ●Clean the solenoid valve body ●Repair the external leakage
The lifting speed is slow or oil flows out of the oil fill cap	<ul style="list-style-type: none"> ●Air and oil are mixed ●Air and oil suction are mixed ●Oil return pipe is loosened 	<ul style="list-style-type: none"> ●Replace the hydraulic oil ●Fasten all the suction pipe fittings ●Re-install the oil return pipe
The lift can't rise horizontally	<ul style="list-style-type: none"> ●Balance cable is not adjusted properly ●The lift is installed on the slop floor 	<ul style="list-style-type: none"> ●Adjust the balance cable to the proper tension ●Shimming the columns to level the lift (no more than 5mm), If exceeding5mm, pour new concrete floor and make it leveled. Refer to installation description.
Anchor Bolt is not fastened	<ul style="list-style-type: none"> ●Hole is drilled too big ●Concrete floor thickness or fastening force is insufficient . 	<ul style="list-style-type: none"> ●Pour the fast curing concrete into the big hole and reinstall the anchor Bolt , or use new drill to drill the hole for re-positioning the lift ●Cut open the old concrete and make new concrete slab for the lift. Refer to installation description.



If the problems remain unsolved, call for technical support.

6. Repair and Maintenance

Keep clean

- This unit should be cleaned with dry cloth frequently to keep it clean. Before cleaning, first switch off the power to ensure the safety.
- The working environment of this unit should be clean. In case of dust in the working environment, it will speed up the parts wearing and shorten the service life of the lift.

Every day:

- Before the operation, carefully check the safety mechanism of the lift to ensure the electromagnet suction and release action is proper, and the safety plate is in good condition. When finding any abnormal situation, make adjustment, repair or replacement immediately.
- Check to see if the steel cable connection is proper, and if the tension is at the optimum status.
- Check to see if the connection between hydraulic cylinder and carriage is proper, if the connecting nut between the steel chain and carriage is loose or falling.

Every day:

- Retighten the anchor bolts.
- Lubricate chains/cables.
- Check all the chain connectors, Bolt s and pins to ensure correct installation
- Check all the hydraulic lines for wearing
- Check to see if the carriage and the inner side of the ^[L]_{SEP} column are properly lubricated. Use high-quality heavy lubrication grease (lithium based lubrication grease GB7324-87).



Note: All the anchor Bolt s should be tightened completely. If any screw doesn't function for some reason, the lift can not be used until the bolt is replaced

Every six months:

- Check all the movable parts for possible wearing, interference or damage.
- Check the lubrication of all the pulleys. If the pulley has dragging during the lifting and lowering, add appropriate lubricant to the wheel axle.
- When necessary, check and adjust the balancing tension to ensure the horizontal lifting and lowering.
- Check the verticality of the column.



Note: The inner corner of each column should be lubricated with lubricant, to minimize the roller friction and ensure the smooth and even lifting.

Maintenance of hydraulic system:

- Clean and oil change In the six months after initial use of this unit, clean the hydraulic oil tank and replace the oil, later clean the hydraulic system once a year, and replace the oil. See Fig. 7
- Replace the seal After this unit is put into operation for certain period, if finding the oil leakage, carefully check it;

if the leakage is due to the wearing of sealing materials, immediately replace the worn one based on the original spec. See Fig. 7

Diagram of hydraulic line of base frame 2-post lift

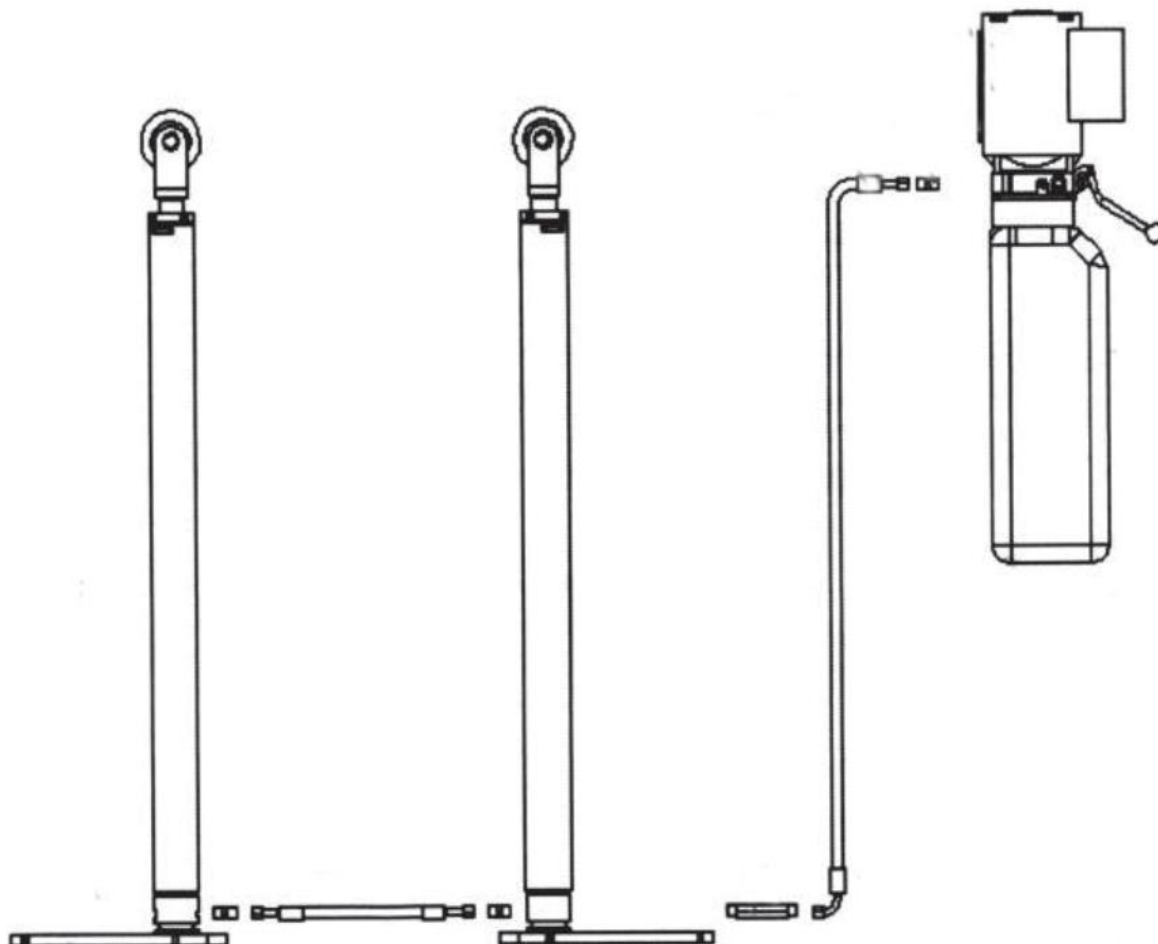

Fig.7a

Diagram of hydraulic line of cross beam 2-post lift

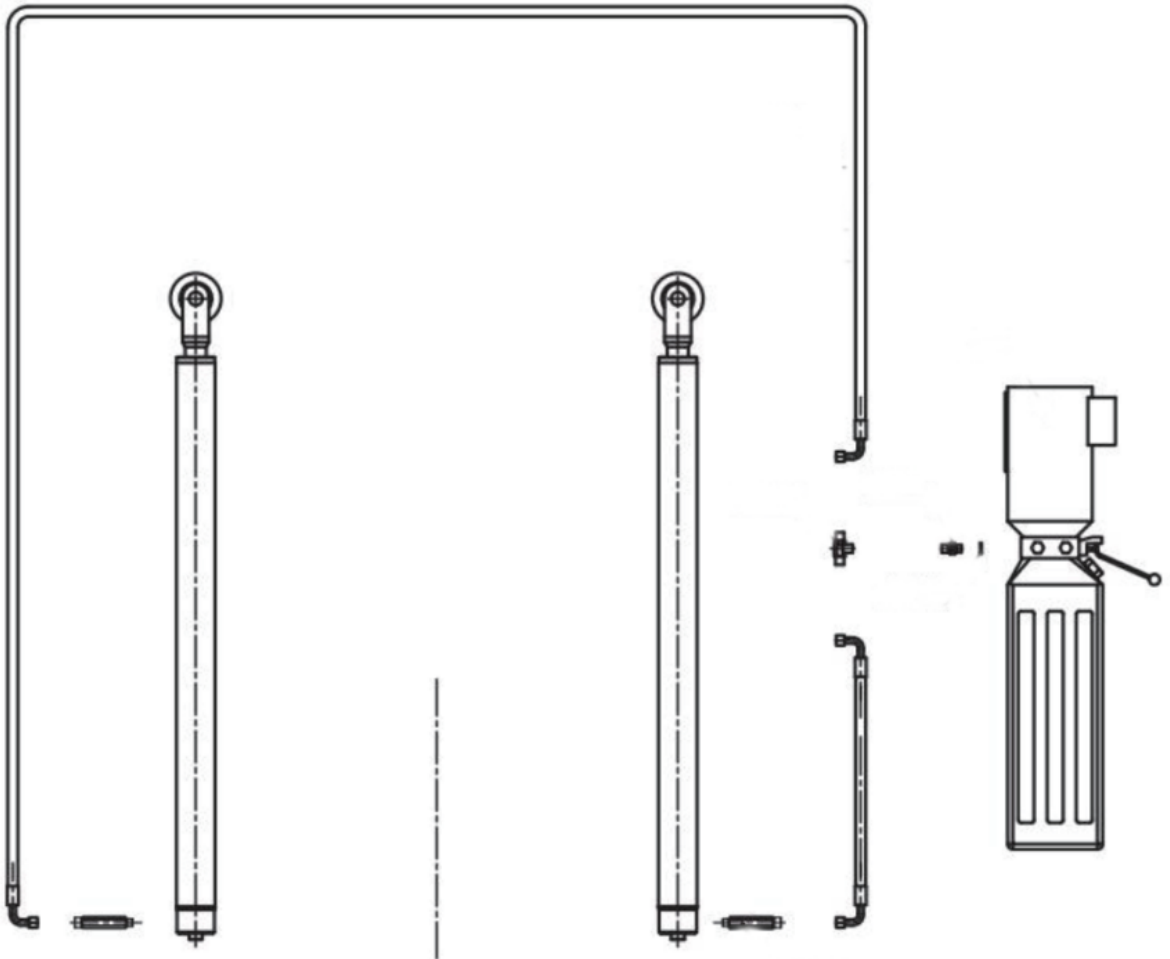

Fig.7b

7. Storage and Scrap

7.1 Storage

- When the equipment requires long-time storage:
- Disconnect the power supply
- Lubricate all the parts requiring lubrication: mobile contact surface of the carriage, etc.
- Empty all the oil/liquid storage units
- Put the plastic cover over the equipment for dust protection.

7.2 Scrap

When the equipment service life is expired and can no longer be used, disconnect the power supply, and properly dispose of as per relevant local regulations.

8. Tools for Installation and Adjustment

To ensure proper installation and adjustment, please prepare the following tools:

Tool	Model
Leveling instrument	Carpentry type
Chalk line	Min 4.5m
Hammer	1.5kg
Medium crescent wrench	40mm
Open-end wrench set	11-23mm
Ratchet socket set	
Flat screw driver	150mm
Rotary hammer drill	19mm
Concrete drill-bit	∅ 19mm

9. Unpacking

- Open the packing box; remove the packing materials and inspect the lift for any sign of shipment damage. Check by packing list to see if the main parts and accessories are complete.
- Keep the packing materials away from the children to avoid danger; if the packing materials cause the pollution, they shall be treated properly.

10. Installation

10.1 Important notice

- The wrong installation will cause the lift damage or personal injury. The manufacturer will not undertake any responsibilities for any damage caused due to incorrect installation and usage of this equipment, whether directly or indirectly.
- The correct installation location shall be “horizontal” floor to ensure the horizontal lifting. The slightly slope floor can be corrected by proper shimming. Any big slope will affect the height of the lifting pad when at the bottom or the horizontal lifting. If the floor is of questionable slope, consider a visual inspection, or pour a new horizontal concrete slab if possible. In short, under the optimum horizontal lifting status, the level of the lifting relies on the level of the floor where it is

installed. Don't expect to compensate for the serious slope.

- Don't install the lift on any asphalt surface or any surface other than concrete. The lift must be installed on concrete floor conforming to the minimum requirement showed in this manual. Don't install the lift on the concrete with seams or crack and defect. Please check together with the architect.
- Without the written approval of the architect, don't install the lift on a second floor with basement.
- Overhead obstruction: The lift installation area can't have any overhead obstruction, such as heater, building support, electrical pipe, etc.
- Concrete drilling test: The installation personnel can test the concrete thickness at each site by drilling test. If several lifts are installed at one place, it is preferred to make drilling test in each site.
- Power supply: Get ready the power supply before the installation. All the electric wiring and connecting should be performed by a certified electrician.

10.2 Installation Procedure

10.2.1 Selecting installation site

Selecting installation site based on the following conditions:

- Lift can only be installed on concrete slab, which must have a minimum thickness of 250mm. and should be aged 7days at least.
- The concrete slab shall have reinforcement by steel bar.
- The concrete slab must be leveled.
- If the thickness of the whole ground concrete is greater than 250mm., the lift can be installed directly
- Check the possible obstruction, e.g. low ceiling, top ^{PIPE} pipeline, working area, passage, exit, etc.
- The front and back of the lift should be reserved with sufficient space to accommodate all the vehicles (Fig.8).
(evaluating from the center line ,each edge should be about 4m)

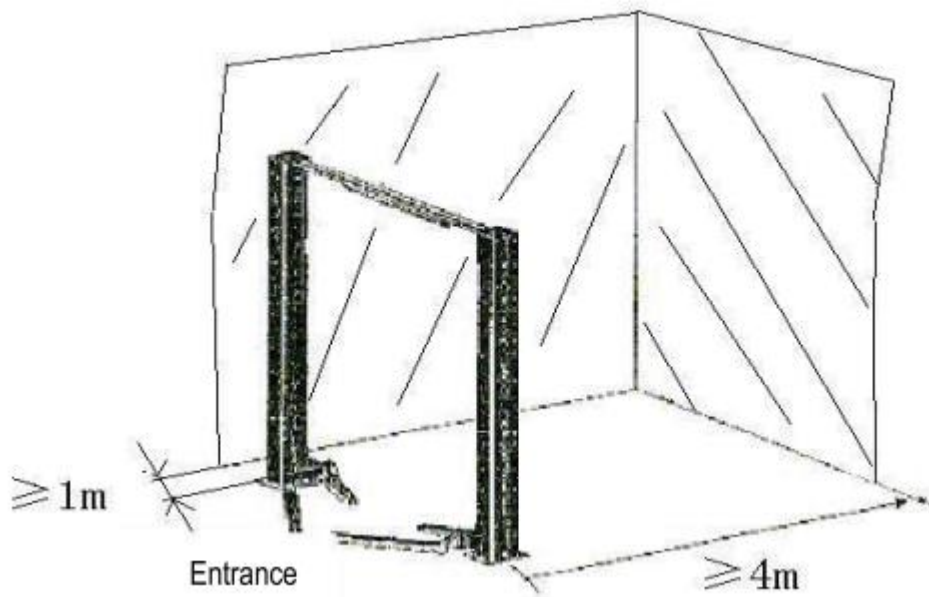

10.2.2 Base frame layout

Floor Plate Lift and Clear Floor Lift symmetric installation is shown in Fig. 9.

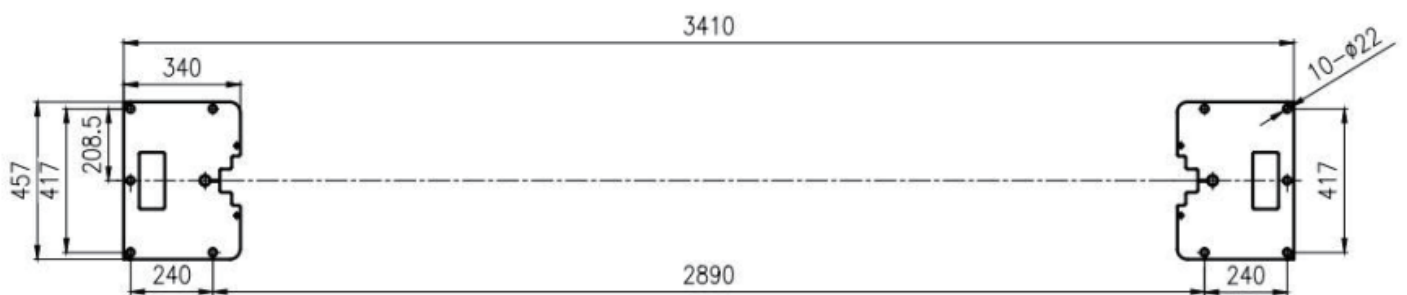

Fig.9



Note

- All the dimensions are based on the external border of the base plate.
- Ensure the overall error is controlled within 6mm. In this way, the difficulties in the final assembly, or early wear or non-alignment of the chain can be eliminated. The marking and layout is very important. If it is inaccurate, there will be problems during the final assembly and operation.

10.2.3 Install the power side column

For base frame and cross beam two post lift ,first install extension column with column, then use lifting equipment to place power side column upper right to the location. Align the base plate of column with the chalk line layout. Guided by holes on the base plate of the column, use 5 concrete anchor bolts to fix it onto the ground. Drill and install anchor Bolt s at one time, during the drilling process, ensure no movement of the column.(Fig.10).

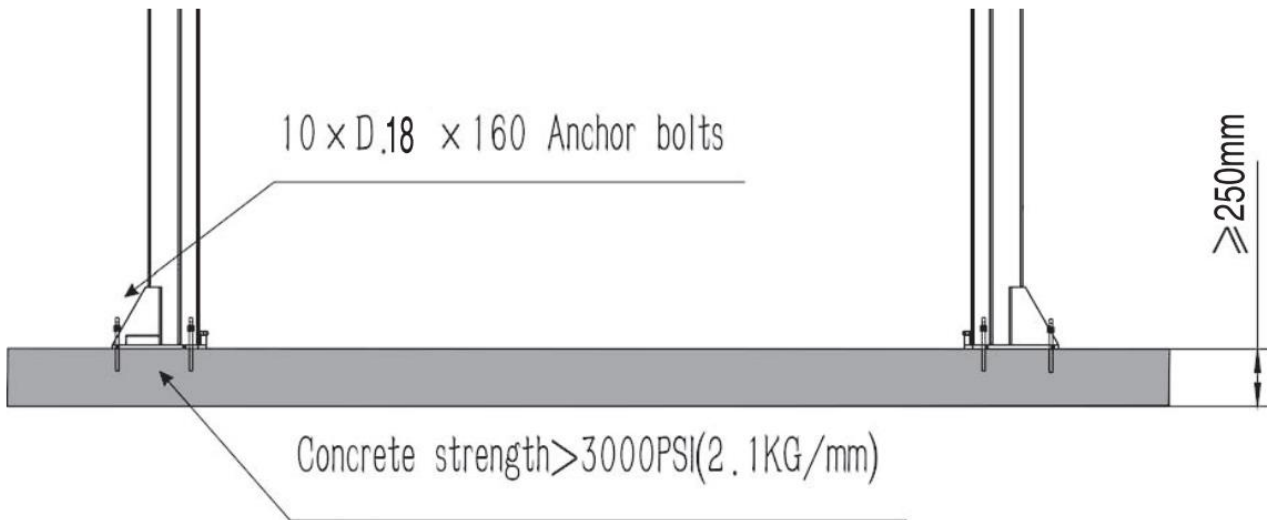

Fig.10

 **Note:**

- Use sharp $\Phi 19\text{mm}$ concrete drill-bit to drill the holes so as not to drill the hole too large,. Use proper pneumatic tool to remove the dust from the hole. The depth of the hole is the same as that of the anchor Bolt . Insert the anchor Bolt and make the washers lean against the base of the column.
- Only use torque wrench instead of impact tools to fasten anchor bolts.

- *Insert proper steel shim under the base seat of column to plumb the column.*



Note: The thickness of shims shouldn't exceed 5mm.

To get the correct and safety installation, please follow the following installation steps.

- Wear the safety goggles
- Use hard alloy drill-bit.
- Don't use the drill-bit with wearing exceeding the tolerance.
- The drill and concrete surface should be kept perpendicular.
- Let the drill work itself. Don't apply the extra force, and don't ream the hole or allow the drill to wobble.
- The drilling depth of hole is based on the length of anchor Bolt .The distance from the Bolt head to the concrete floor should be more than twice of the Bolt diameter.
- Remove the dust from the hole.
- Gently tap the Bolt into the hole till the washer rests against the base plate of column.
- Fasten Bolts

10.2.4 Raising



During raising and lowering cycles: Closely watch the vehicle and the lift, do not allow anyone to stay in lift area and make sure the vehicle doors are closed.

Once the disk adapters contact the lift points, check arm restraints for engagement. After raising the vehicle briefly, stop and check adapters for secure contact.

- Press button on power unit.
- Lift stops once button is released or upward travel limit is reached.

When vehicle is in raised position:

- Slowly position vehicle midway between adapters. Apply the parking brake.

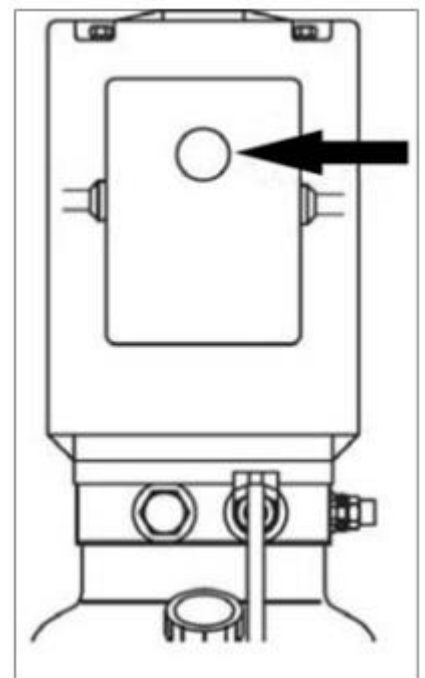

- Swing and telescope arms as required to position adapters under vehicle manufacturer's recommended lift points.
- Turn the disk adapters that they evenly contact all four lift points. Once the disk adapters contact the lift points, check arm restraints for engagement. If necessary, slightly move the arms until the gear segments mesh. Never unlatch the arm restraints when the lift is under load.
- Leave vehicle and remain clear of lift. Always lift the vehicle using all four adapters.



Once the disk adapters contact the lift points, check arm restraints for engagement. After raising the vehicle briefly, stop and check adapters for secure contact.

- Press button on power unit. Lift stops once button is released or upward travel limit is reached. When vehicle is in raised position: Observe all accident prevention regulations.
- Do not allow unauthorized persons to stay under the raised vehicle.
- Avoid rocking of vehicle.
- Keep lift free of tools, parts, etc.
- Keep lift free of tools, parts, etc.
- Fasten the vehicle to the support arms using lashing straps when removing or installing heavy components.

10.2.5 Locking & Lowering

Locking

- The latch mechanism will 'trip over' when the lift raises and drop into each latch stop. But, to lock the lift you must press the lowering lever to relieve the hydraulic pressure and let the latch set tight in a lock position.



Always lock the lift before going under the vehicle. Never allow anyone to go under the lift when raising or lowering. Read the safety procedures in the manual.

Lowering



During raising and lowering cycles: Closely watch the vehicle and the lift, do not allow anyone to stay in lift area and make sure the vehicle doors are closed.

- Raise the lift until the latches clear the safety racks in both sides.
- Press the lever at the power unit to lower the lift.

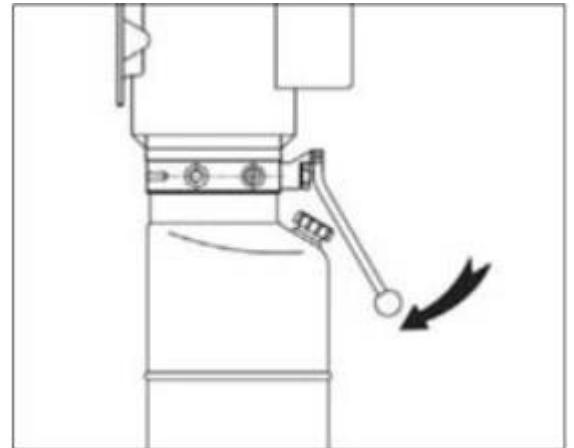

Warning: Always make sure safety latches on both sides clear the rack at same time when pulling down the release handle by adjusting the cable.

10.2.6 Install and adjust the balancing steel cables

Raise the two carriages to the safety locking position, make sure the two carriages are of the same height from ground.

For **clear floor** models, route the steel cables as Fig. 11b shows ,for **floor plate** models,route the steel cables as 11a shows.Adjust the tension of cables through the adjustment nuts on each end of steel cable. The steel cables should be tight in equal tension. Each steel cable should be ensured in the pulley when adjusting tightly, otherwise the steel cable will be damaged.

 **Note:** Before operating the lift, re-check the balancing steel cables and ensure they are not crossing or wrongly installed. Ensure the steel cables still in the pulley.

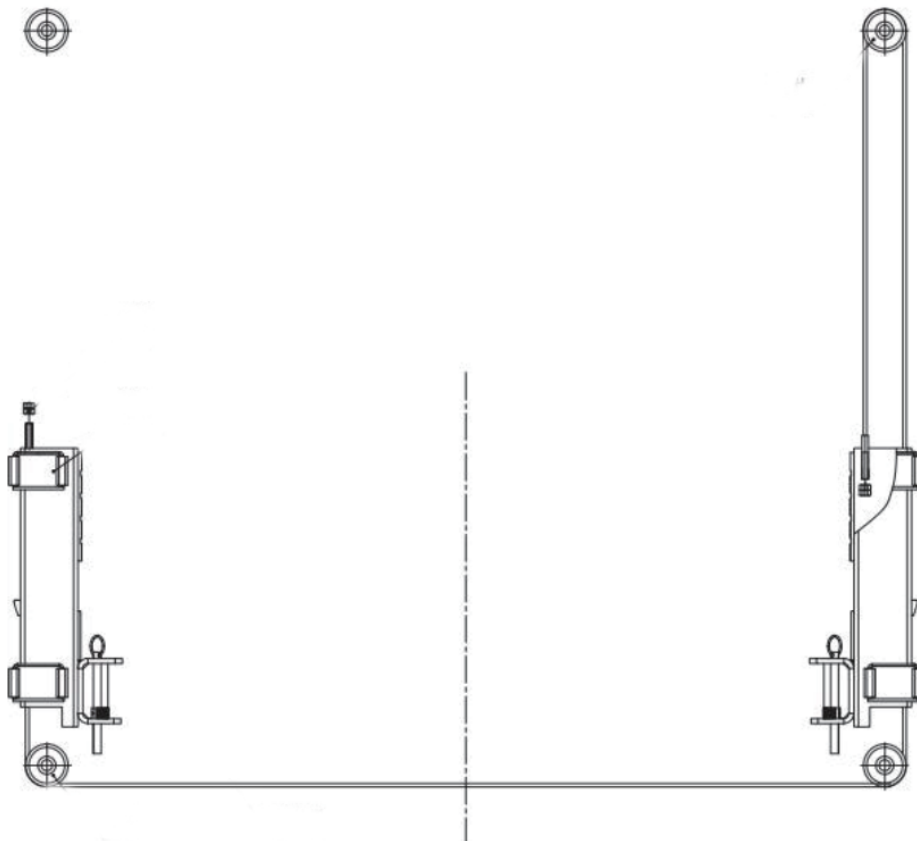

Fig.11a

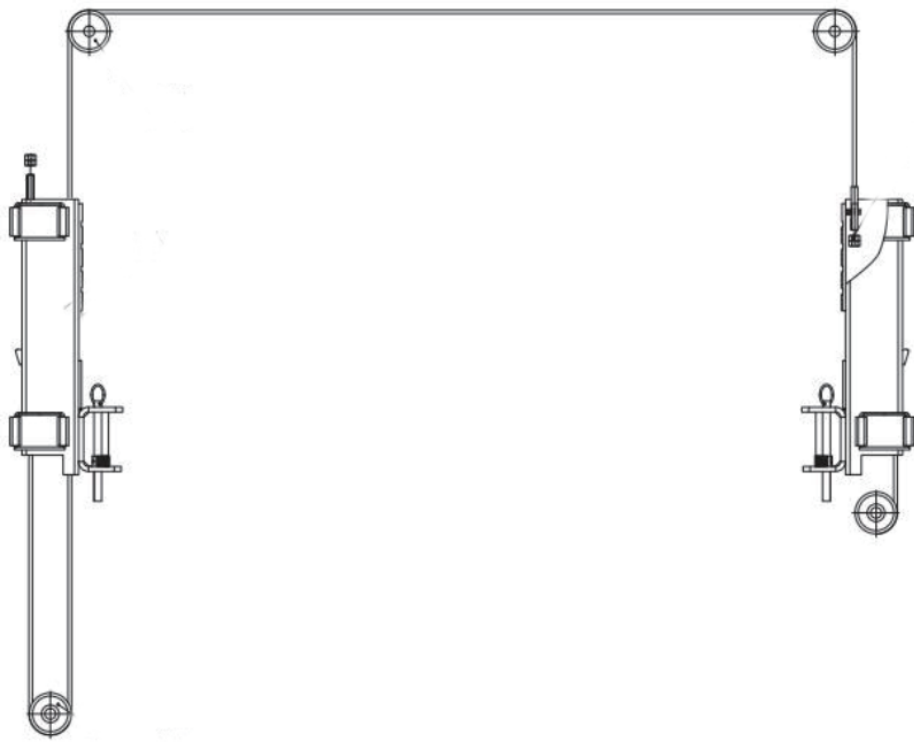

Fig.11b



Note: The two steel cables shall be adjusted to certain uniform tension to ensure the two carriages are moving synchronously.

10.2.7 Install the power unit and hydraulic lines

- Use two M10 Bolt s and washers to fix the power unit (as shown in Fig. 12a、 12b). for **clear floor** models, install the hydraulic line as shown in Fig. 12b, for **floor plate** models, install the hydraulic line as shown in Fig. 12a and tighten all the fittings top revert oil leakage.
- Fill the reservoir with hydraulic oil (oil capacity of 10L). Operate carefully to avoid dust and other pollutants mixed with the hydraulic oil.



Note:

- *Clean the impurities in the hydraulic line and remove the protective plug from the hydraulic cylinder.*
- *When the hydraulic hose installation needs to go through the column, ensure the hydraulic hose won't touch any movable parts inside the column*

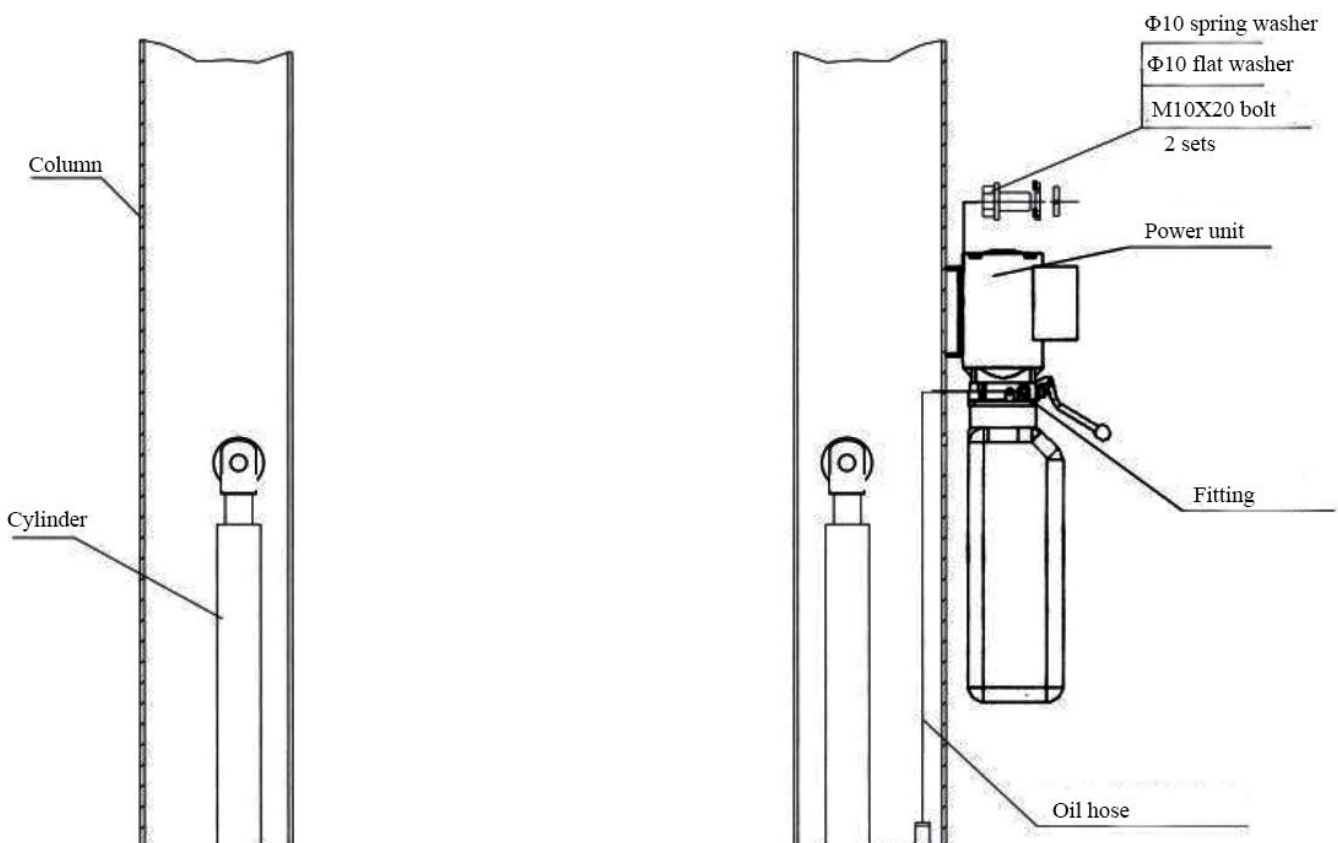

Fig.12a

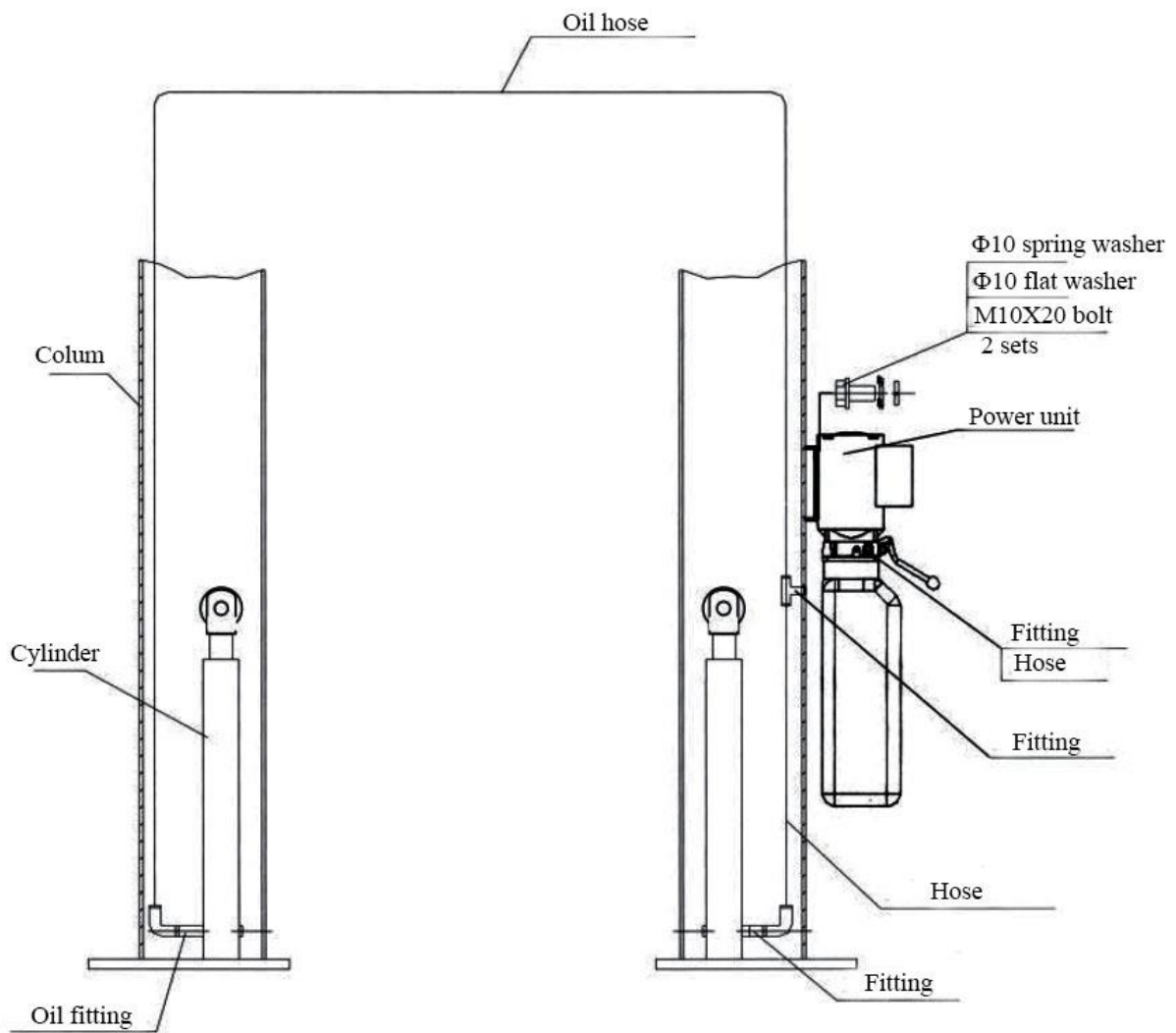

Fig.12b

10.2.8 Install the swing arm

Install the swing arm as shown In Fig.13



Note:

Before use ,check if the positioning gear mechanism at the end of arm fits, adjust the Screw s of fixed semi-gear for its fitness.During the installation, lubricate the moving parts of swing arm and carriage if accessory, so that the swing arm can move freely.

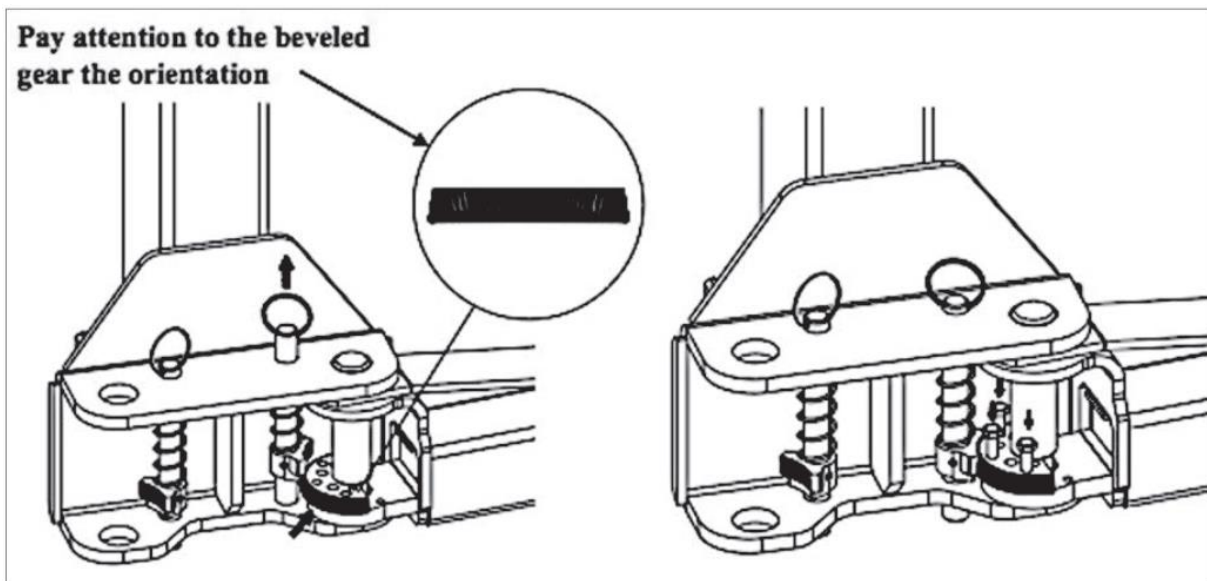
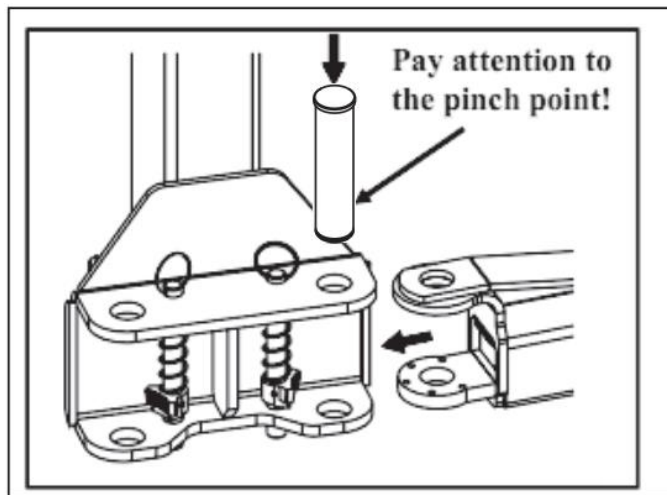

Fig.13

11. Lift Adjustment

11.1 Preparation before the adjustment

- Lubricate contact surface of the carriage and corners of column with general-purpose lithium grease. All sliding surface should be coated evenly from top to bottom.
- Fill hydraulic oil N32 or N46 to the oil reservoir of the power unit. ^[1]_{SEP}

11.2 Adjustment procedure ^[1]_{SEP}

- Check to see if the power supply is installed properly.
- Check for the tightness of all the connecting bolts. ^[1]_{SEP}
- Raise the carriages to check the equalizer cable tension by grasping the adjacent cables between the thumb and the forefinger so that you can just pull the cables together. Adjust the nuts on the carriage if necessary.
- Press the starting button on the motor, and the carriage rises; stop pressing the button, then the carriage will stop.
- In order to lower the carriage, first pull the steel rope for releasing safety locks on the two carriages one time for each. In case of failure to pull the wire, re-pull after raising carriage a little. Press the lowering handle on the power unit and the carriage will be lowered; stop pressing the handle, then the carriage will stop. In case of vehicle repairing, when the vehicle is lifted up to the required height, first press the oil release handle to actuate the mechanical safety lock in order to ensure the safety operation.
- The hydraulic system may contain air due to new installation, to bleed the air, repeat the lifting and lowering for several times.
- The adjustment is completed.

DECLARATION OF WARRANTY AND LIMITATION OF LIABILITY

The manufacturer has paid proper attention to the preparation of this manual. However, nothing contained herein modifies or alters, in any way, the terms and conditions of manufacturer agreement by which this lift was acquired, nor increase, in any way, manufacturer's liability to the customer.

TO THE READER

Every effort has been made to ensure that the information contained in this manual is correct, complete and up-to date.

The manufacturer is not liable for any mistakes made when drawing up this manual and reserves the right to make any changes due the development of the product, at any time.

WARRANTY CERTIFICATE

The warranty is valid for a period of 12 months starting from the date of the purchase invoice. The warranty will come immediately to an end when unauthorized modifications to the machine or parts of it are carried out. The presence of defects in workmanship must be verified by the Manufacturer's personnel in charge.

TECHNICAL SERVICING

For all servicing and maintenance operations not specified or shown in these instructions, contact your Dealer where the machine has been bought or the Manufacturer's Commercial Department