

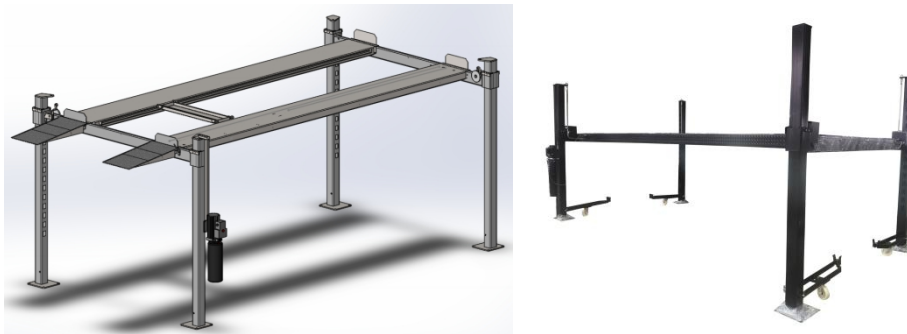

## FP11000

### FOUR POST LIFT

## INSTALLATION AND OPERATION MANUAL



**Note:** By starting the installation and operation, you thoroughly understand the details in this manual and assume full responsibility for product use. Your safety also depends on proper training and thoughtful operation. Do not install, operate, maintain, or repair the unit without reading and understanding this manual and the labels on the unit; do not use the Lift unless you can do so safely! Never exceed the rated capacity of the Lift

CHAMPION free from liability for damages resulting from:

- Use of the equipment for purposes other than those described in this manual.
- Modifications to the equipment without prior, written permission from CHAMPION.
- Injury or death caused by modifying, disabling, overriding, or removing safety features.
- Damage to the equipment from external influences.
- Incorrect operation of the equipment.

### Unit Information

Model:	
Serial:	
Manufacture Date:	

## 1, Introduction

This manual is mandatory reading for all users of these Lifts, including anyone who installs, uses, maintains, or repairs them. Keep this manual on or near the equipment so that anyone who uses or services it can read it.

Sleeve type design makes the lift steady .Long and high runways with 11000lbs capacity. Never exceed the rated capacity of the Lift.

Note: The Runways supports less weight than its rated capacity if the Vehicle's wheelbase is shorter because the wheels of such a Vehicle are closer to the middle of the Runways, where there is less strength.

## 2, Specifications

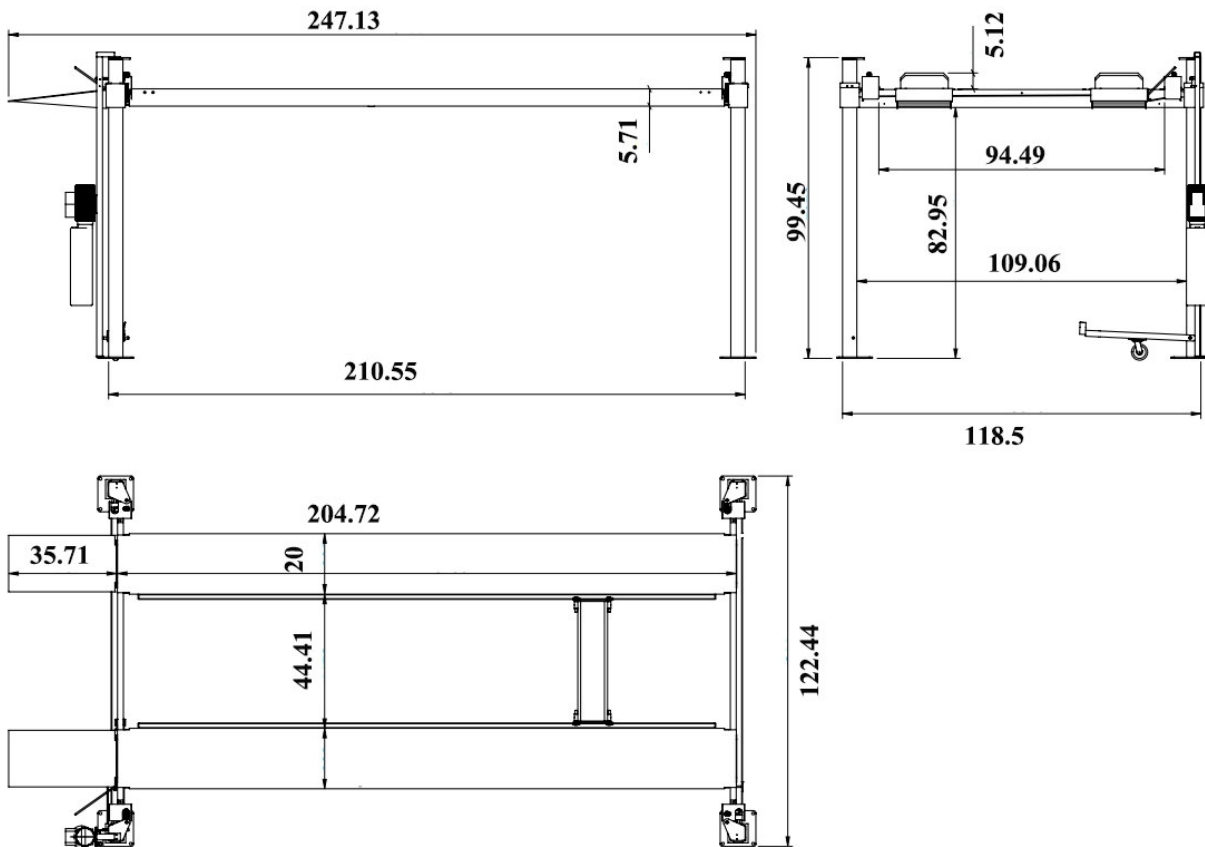

Specifications subject to change without notice.

### ***3,Installation***

!Only use the factory-supplied parts that came with your Lift. If you use parts from a different source, you void your warranty and compromise the safety of everyone who installs or uses the Lift. Do not install this equipment unless you have automotive Lift installation training. Always use proper lifting tools, such as a Forklift or Shop Crane, to move heavy components.

!You should have at least one assistant during installation. Three assistants are preferred.

Tools you may need:

- Rotary Hammer Drill (If Anchoring)
- 3/4" Masonry Bit (If Anchoring)
- Hammer
- 4 Ft. Level
- Open-End Wrench Set Metric
- Socket and Ratchet Set
- Hex-Key / Allen Wrenches
- Material Handling lift
- 2 Ton Engine Hoist or Come-Along

- Car Dollies or Skates
- Medium Crescent Wrench
- Medium Pipe Wrench
- Pry Bar
- Chalk Line
- Medium Flat Screwdriver
- 25" Tape Measure
- Needle Nose Pliers
- Locking Pliers

### **Selecting Location**

You must consider some factors when selecting a location to install the lift, including the available space, all around the lift's clearance, power source and the floor and so on.

\*Only install the Lift on a level floor . If your floor is not level, consider making the floor level or using a different location.

\*Make sure the concrete is at least 300mm thick,  $\geq$ C25, and use after a minimum of 28 days if it is newly concreted floor.

\*Do not install this lift outdoor.

Note: You should also think about the orientation of the lift before installation, which depends on the power source and your convenience. The lift can be turned by 180 degree, while the ramps can be installed on either end.

### **Chalk Lines**

Make the chalk lines as per lift specifications and at last to confirm that the diagonals equal.

### **Unloading**

Some components are very heavy, you need to use forklift and shop crane to move them to the installation position. You should move the components as close as possible to the installation position, which can make your installation work easier.

## Posts and crossbar installation

① Move the posts carefully into the chalk lines inner corners with a forklift or shop crane. When you put the posts into position, make sure that all four posts are oriented so that the safety lock holes are near the end of runways and face to face with the holes of the other post at the same lift end.

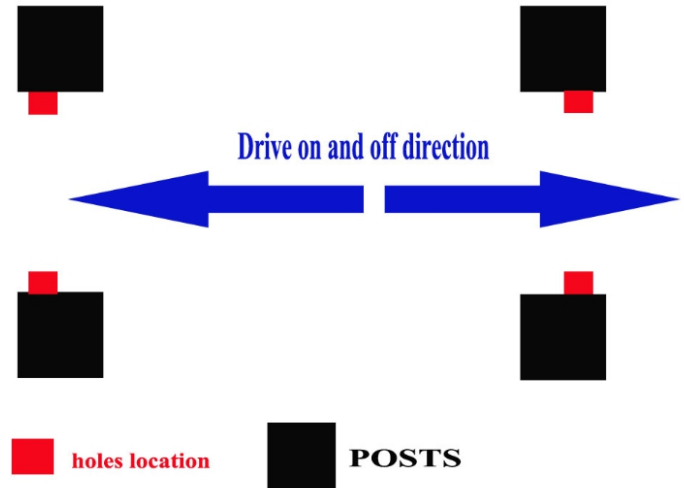
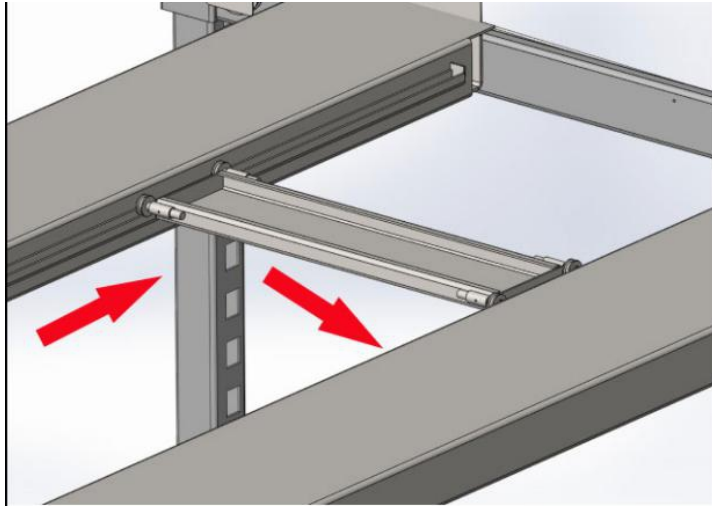

**Recommendation: Our lifts are designed and manufactured in perfect performance, but wax the outside of the posts with paste wax or spray wax can reduce friction and keep smooth operation. Do not recommend to use grease, which will make it dirty.**

② Stand up them now. Have at least two people to work together. Do not anchor them at this stage. And pay attention when you walk around the posts, they are not anchored and easy to be knocked over.

③ Get sleeves over the posts: There are two methods.

\* With the posts standing up, raise the crossbar over the tops of the posts and slide down around the posts.

\* With the posts laying down, make the sleeves over the tops of the posts and slide around the posts. And then stand the posts back up.

**Please go slowly and squarely as not to scratch the paint. To protect the paint, you can put two pcs of slide blocks first at diagonal corners.**

Caution: The posts are not anchored at this point, you must use a proper device like forklift or shop crane and make sure at least two people to work on this. And pay attention to the posts, prevent it falling on people.

④ Insert the remaining UHMW slide blocks into the sleeves and it will work between the posts and the sleeves. There are totally 4 pcs at the corners of the posts. You can shake the posts slightly for easily inserting the blocks. And then install the block covers.

⑤ Raise the crossbar up with a forklift or shop crane, about minimum 60cm off the floor. This makes it easier to finish the rest of the installation work. The two crossbars must be raised to the same height and engaged at the same primary safety lock. But make sure the slack safety locks are not engaged.

## Installing the runways

The runways are very long and heavy, make sure to use forklift or shop crane to install them. There are 2 runways for each lift. One with hydraulic cylinder and the other without. Make sure the rails of the runways orient inward.

## Lock release assembly installation

You can manually release all the four locks by one handle. Most parts are already assembled, which is easy for you to install it.

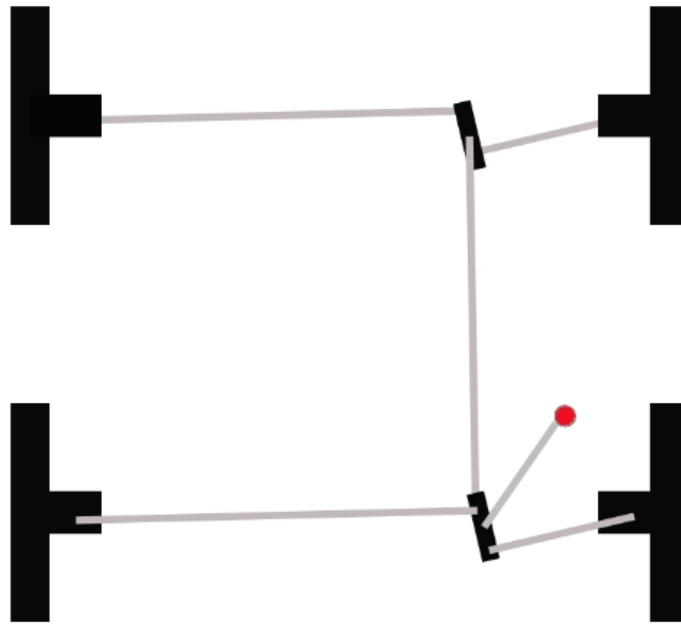

Note: This lift has 2100mm lifting height, if it is too high for you to touch the release handle when it stopped on the highest level, do not worry, there is a special design for the handle. You will find a small hole in the rod. You can please put a steel cable or rope through the hole and then you can easily touch it and release the lock.

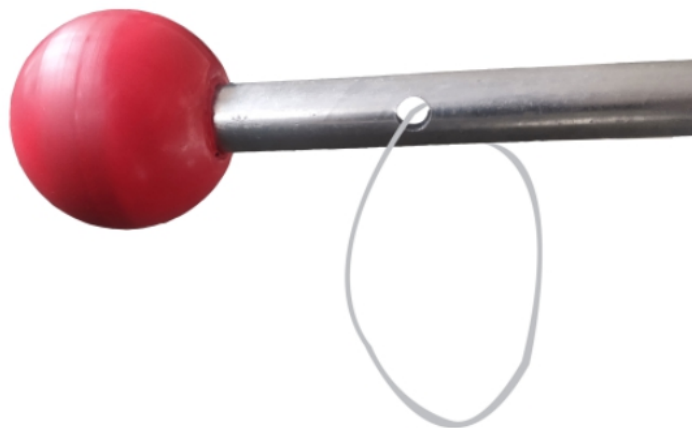

### Install the top caps

There are 4 top caps, and only one with the holes to fix the power unit mounting bracket. Each cap holds one end of a lifting cable. Insert the top caps into the columns. The caps have some additional materials added to the sides, so they can be fully seated, no need to be bolted.

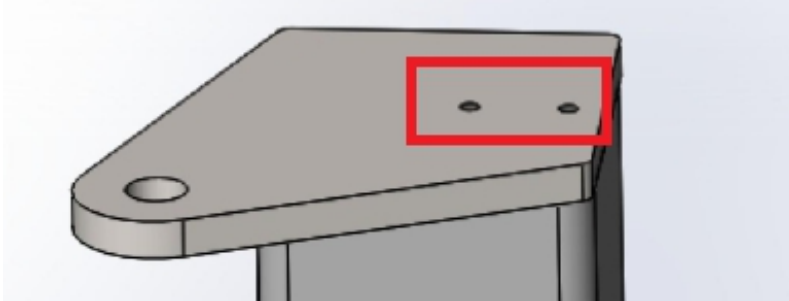

Note: All four Top Caps must be oriented so that the extended corner is angled in towards the middle of the Lift.



**At last, Installing cables and the power unit.**

## ***4,Operation***

### **Raise the runways:**

\*Press and hold the ***up*** button on the power unit.

\*When the runways go to the desired height,go up a little higher,release the up button and then press and hold the ***lowering handle***,the runways will go down to the safety locks and you can release the lowering handle after the runways stop moving for several seconds.

Please do not press the lock release handle during this process,it will prevent the lock engaging.

### **Lower the runways:**

\*Press and hold the ***up*** button for around 2 seconds for the runways rising and make some space to release the lock.

\*Press and hold the ***lock release handle first*** to make sure all the four locks are released.Then press and hold the ***lowering handle*** to lower the runways.

Note:Only keep the runways either engaged on the same Safety Locks or fully lowered.

## ***5,Maintenance***

### **• Daily:**

1,Keep the Lift clean. Wipe up any spills, clean any dirt.

2,Make a visual inspection of all moving parts and check for damage or excessive wear. Replace any damaged or worn parts before using the Lift.

3,Make sure all Safety Locks are in good operating condition. Do not use your Lift if the Safety Locks are damaged or excessively worn.

### **• Monthly:**

1,Check all labels on the Lift. Replace them if they are illegible or missing.

2,Grease all lubrication points on the Lift.

3,Check Hydraulic Fluid levels. Refill if low.

4,Lubricate the wire rope (Cables).

5,Check Cable connections, Bolts, and Pins for proper mounting and torque.

6,Check all Anchor Bolts to make sure they are properly torqued. If they are loose, tighten them.

Wire rope should be replaced when there are visible signs of damage or extreme wear. Do not use the Lift if it has damaged or worn Cables.